

Hardware technology
for glass doors

STUDIO Hardware



STUDIO OLIS
STUDIO ALEA
STUDIO VENA
Accessories



Contents

General information Page 3
 New perspectives through innovations..... Page 3
 Top quality finishes..... Page 3
 Quality – Made in Germany Page 4
 Notes on use with laminated safety glass Page 5
 Corrosion protection classes according to DIN EN 1670 Page 5
 Various possibilities for the highest of demands Page 6
 Benefits of consistent further development Page 7



STUDIO OLIS Page 8



STUDIO ALEA..... Page 20



STUDIO VENA..... Page 32



Accessories Page 42

Appendix Page 60
 Glass processing Page 60
 Door weights..... Page 64
 Installation details..... Page 66
 Materials and finishes Page 73
 Index Page 74
 General overview: Locks and hardware for glass Page 79

New perspectives through innovations

STUDIO hardware for interior doors combine design with functionality. Top quality finishes and modern shapes meet innovative technology.

For use in residential homes or commercial properties such as administrative buildings, hotels and retirement homes, our assortment offers the complete range of features needed to equip a wide variety of rooms.

In the STUDIO series, you can choose between three versions: OLIS, ALEA and VENA. The locks offer a lot of advantages such as low-wear, polyisocyanate springs, a noise-reducing latch, a slim handle guide and an optimum hold for square spindles thanks to a new clamp follower. The handle resistance can also be infinitely adjusted.

All of the locks are also available with a flat clamping plate, magnetic latch and in a lockable, non-protruding version for use in narrow frame profiles.

The locks have been tested under DIN EN 12209. We offer a 5-year warranty. Reliable quality is your advantage.

The locks and hinges are suitable for 8 and 10mm safety glass. Instructions for use with laminated safety glass can be found on page 5.

Further products such as door handles, frame parts and door gaskets complete the extensive programme.

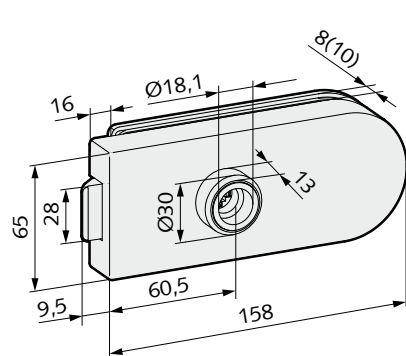

STUDIO OLIS

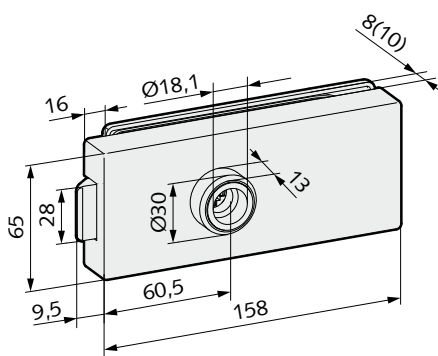

STUDIO ALEA

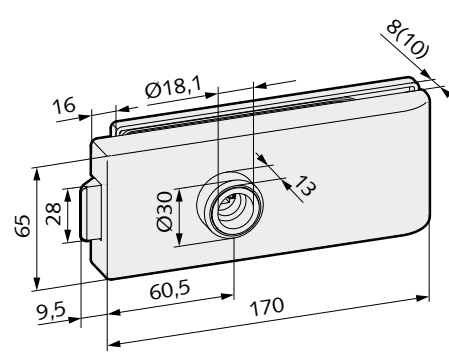

STUDIO VENA

Top quality finishes

The individual and top quality look of your glass door only really becomes perfect with a top quality finish on the hardware.

The finish is affected by two parameters: the structure and colour. The structure of our locks and hardware is polished and brushed (E4) to achieve the best possible finish.

The colour of the anodized aluminium finishes is based on the EURAS standard colour swatch. The colour C-0 (---.112) is a silver anodized finish, C-31 (---.137) is a stainless steel anodized finish.

With the stainless steel finish (---.198), you hardware are given a particularly high quality, modern stainless steel look. The finish is 100% identical to a matt V2A stainless steel on the basis of top quality aluminium.

Make your mark with our top quality finishes. Details on other finishes that are available can be found in the individual chapters, or get in touch and tell us what you need.



E4/C-0
silver anodized
(---.112)



E4/C-31
stainless steel anodized
(---.137)



stainless
steel finish
(---.198)

Quality – Made in Germany



A good idea is the beginning to every product. A team of highly qualified designers and engineers at our headquarters in Heiligenhaus develops products of an outstanding quality in a continuous dialogue with you, our customers.

One important element is a modern production plant in which the processes are subject to constant monitoring and control, so only the best products pass through our test benches. Cycle testing, salt spray and overload tests – we put our products through their paces.

We gather knowledge and develop it further thus manufacturing products that get established in the market thanks to their durability, quality and design.

Naturally, our design, development and production plant is certified to DIN EN ISO 9001:2015 standards.

Large stocks of standard products, short delivery times and decision paths allow the prompt and uncomplicated processing of your orders. We act fast, flexibly, and always in the interest of our customers.

We offer a 5-year warranty on our products in our STUDIO OLIS, STUDIO ALEA and STUDIO VENA series from the date of delivery, assuming correct installation and use.

From the idea to the finished product – WSS creates quality Made in Germany.



Corrosion protection classes according to DIN EN 1670

The locks and hardware in the STUDIO series satisfy corrosion protection class 3, tested according to DIN EN 1670 (use in residential homes and public administrations).

We recommend OBJEKT locks and hardware, tested according to corrosion protection class 4, for doors in high humidity environments. The doors may be exposed temporarily to moisture from water spray or high atmospheric humidity (use: sanitary area and treatment rooms).

We do not recommend using the locks and hardware in swimming pools and salt-water baths with a significant chloride and/or sulphur dioxide load.

Notes on use with laminated safety glass

All of the locks and hardware in this catalogue, with a few exceptions, are also suitable for laminated safety glass (8,76 and 10,76mm) of 2x toughened safety glass. Please contact us to clarify the technical details if necessary.

On account of the special properties of laminated safety glass, we recommend that the locks and hardware be stuck to the glass too.

Our technical information for toughened safety glass applies if laminated safety glass is used with pressure-resistant interlayer.

The use of other laminated safety glasses is at your own risk.

Corrosion protection	Corrosion resistance
Class 0	no defined resistance
Class 1	little resistance
Class 2	moderate resistance
Class 3	high resistance
Class 4	very high resistance

Various possibilities for the highest of demands

Lock types



STUDIO OLIS

STUDIO ALEA

STUDIO VENA*

Locks

with handle guide and high clamping plate (standard latch fitted, noise-reducing latch enclosed)

Non-locking, handle positioned on the reverse side	✓	✓	✓
Non-locking, handle positioned at front	✓	✓	✓
Warded lock with 2 keys	✓	✓	✓
Prepared for profile cylinder	✓	✓	✓
WC lock	✓	✓	–
Striker box, large	✓	✓	–
Striker box, small**	✓	✓	✓

Versions

Flat clamping plate	✓	✓	✓
For door handles with roses***	✓	✓	–
Magnetic latch	✓	✓	✓
Lockable, no projection	✓	✓	✓

Note:

* The locks in the “VENA” series are only available with a flat clamping plate.

** The “Striker box, small” is only available with a flat clamping plate.

*** The “for door handles with roses” versions of the locks are usually supplied with a flat clamping plate.

Benefits of consistent further development



Noise-reducing latch
Also included with the delivery. The noise-reducing latch lets the latch fall against the striking plate gently. Locking noises are reduced to a minimum.

Standard latch
Fitted as standard



Magnetic latch
Optional. In a lock with a magnetic latch, the latch enters the striking plate on its own, quietly and smoothly, when the door is closed. When the door is open, the latch is fully retracted in the lock and does not protrude as in normal locks. The latch is fitted with a "negative" polarity. A magnetic insert and magnetic clips for the frame are also available (see page 58).

Warranty

We grant a 5-year warranty on the products in our STUDIO OLIS, STUDIO ALEA and STUDIO VENA series from the date of delivery.



Application

For use in private and commercial properties

Surfaces

High quality aluminium finishes with a stainless steel finish

Clamp follower

Optimum hold for the square spindle

Lockable, non-protruding
Optionally available for narrow frame profiles in which a projection of the latch and deadbolt is not possible (only 10mm frame depth necessary).

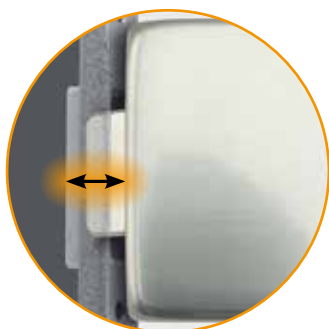

Lock insert
Noise-reducing

Adjustment of the door handle resistance
Progressively with the lock fitted

Polyisocyanate springs

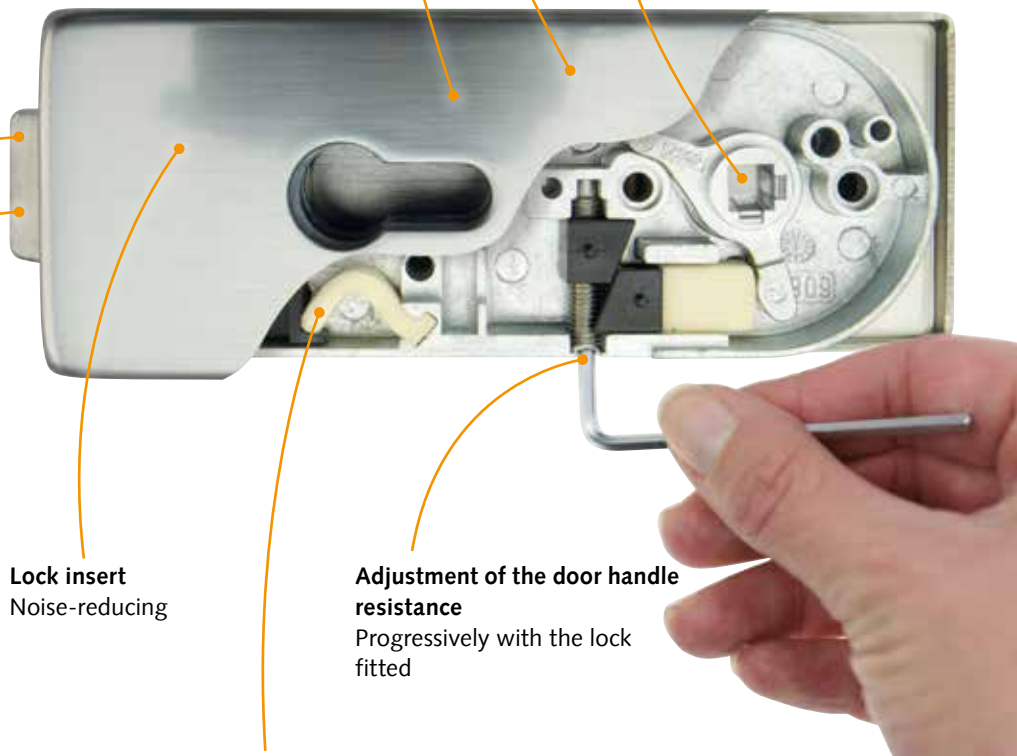



STUDIO OLIS

Quality and technology.

The highest demands on the quality of life and living.

Technical data:

- Glass:**8 and 10mm toughened safety glass
(12mm on request) 8,76 and 10,76mm laminated safety glass of 2x toughened safety glass
- Door weight:**max. 47 kg (hinges for private sector)
max. 60 kg (hinges for commercial properties)
- Door width:**max. 1.000mm
- Frame rebate depth:** ...24 to 45mm possible
- Lock:**analogous DIN EN 12209
tested with 1,5 million closing cycles (specification: 500.000 closing cycles)
- Corrosion protection:** .analogous DIN EN 1670 / Class 3
- Deadbolt projection:**...20mm (1-turn)
- Hinge:**analogous DIN EN 1935 tested with 200.000 closing cycles (private sector) and 500.000 closing cycles (commercial property)
- Use:**Installation in frames according to DIN 18101/18111

Features:

- Locks for use in residential homes and commercial properties
- Hinges optionally for residential homes or commercial properties
- Lock and hinge in a rounded design
- Lock with standard and noise-reducing latch
- Lock can be used on the left/right
- Lock optionally with high or flat clamping plate
- Lock optionally with magnetic latch too
- Lock optionally as lockable, no projection
- Lock with low-wear polyisocyanate springs
- Optimum hold for the square spindle thanks to the clamp follower
- Progressive adjustment of the door handle resistance
- For standard handles with 18mm shoulder guide, optionally also with handle roses
- With 10mm toughened safety glass and 24 mm frame rebate depth, the latch head can be supplied machined

Materials and finishes:

Aluminium	E4/C-0 silver anodized.....	112
	E4/C-31 stainless steel anodized.....	137
	Polished chrome	174
	Stainless steel finish	198
	in special colour anodized.....	199
	RAL 9010 pure white powder coated	250
	RAL powder coated.....	295

Further information:

- Glass processingPage 60–63
- Door weightsPage 64–65
- Installation detailsPage 66–72

UV lock
Handle position front

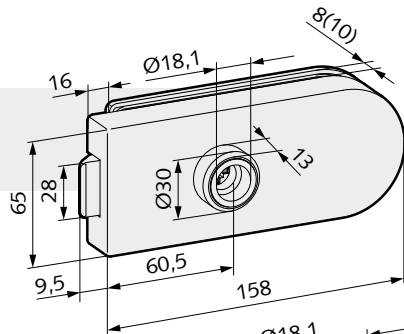

PC lock
prepared for profile cylinder (PC)

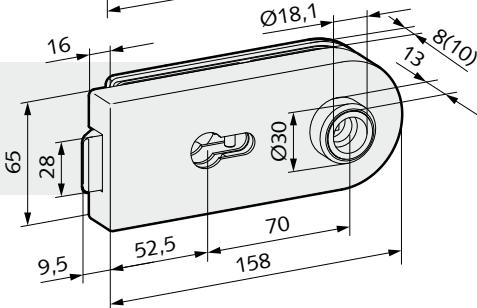

Total thickness: Lock with high clamping plate 45 (47) mm
Lock with flat clamping plate 39 (41) mm

Hinge with sleeve
for 24 mm frame rebate depth (residential homes)

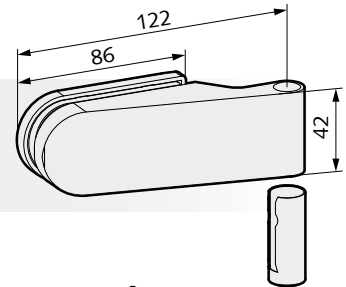

Hinge with sleeve
for 24 mm frame rebate depth (commercial properties)

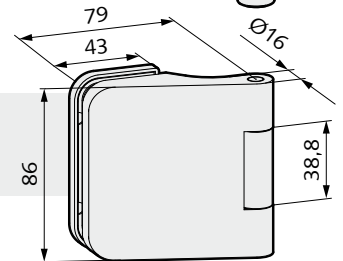

Hinge with fixing plate
for non-rebated door frames (commercial properties)

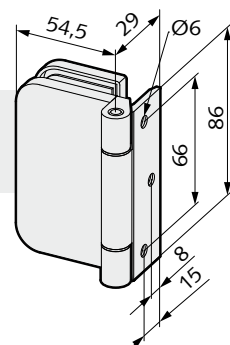

How to choose the right product

The hardware can be ordered as sets or individual components.

Sets (lock **with** hinges) Page 11–13
 Individual components (lock **or** hinges) Page 14–19

We have compiled explanations of the respective tables on the basis of the example “Individual components/PC lock”.

Please use the necessary order numbers from this table.

High clamping plate



Flat clamping plate



The locks are optionally available with a high or flat clamping plate.

PC lock

- Prepared for profile cylinder
- Glass thickness: 8 (10) mm
- Frame rebate depth: 24 (26) mm

With handle guide



With handle guide

Part#	Clamping plate	Latch
20.206.0500.---	high	Standard
20.207.0500.---	flat	Standard

The locks can optionally be supplied with a handle guide or prepared for door handles with roses.

With handle guide
lockable, no projection

Part#	Clamping plate	Latch
20.206.5500.---	high	Standard
20.207.5500.---	flat	Standard
20.206.6500.---	high	Magnet
20.207.6500.---	flat	Magnet

For door handles with roses



For door handles with roses

Part#	Clamping plate	Latch
20.245.0500.---	flat	Standard

For door handles with roses
lockable, no projection

Part#	Clamping plate	Latch
20.245.5500.---	flat	Standard
20.245.6500.---	flat	Magnet

Lockable, no projection

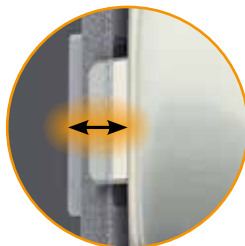

For use in narrow frame profiles
(only 10mm depth needed)

Standard latch

Noise-reducing latch

Magnetic latch

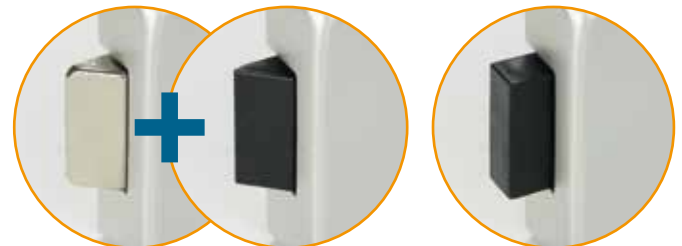

With the “Standard” design, you will receive a lock with fitted standard latch and an enclosed, exchangeable noise-reducing latch. With the “Magnet” design, you will receive a lock with a magnetic latch. A magnetic insert and magnetic clips for the frame are also available (see page 58).

STUDIO locks with STUDIO hinges

Scope of delivery:

- 1 lock with handle guide of your choice
- 2 STUDIO hinges with sleeves

Available finishes:

- .112 Al E4/C-0 silver anodized
- .137 Al E4/C-31 stainless steel anodized
- .198 Al stainless steel finish

- Use in residential homes
- Door weight: max. 47 kg
- Glass thickness: 8 (10) mm
- Frame rebate depth: 24 (26) mm



UV lock

Latch lock, non-locking
handle positioned on the reverse side

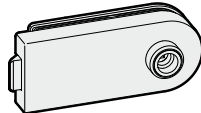

Part#	Clamping plate	Latch
20.100.0500.---	high	Standard
20.101.0500.---	flat	Standard

UV lock

Latch lock, non-locking
handle positioned at front

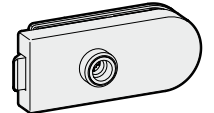

Part#	Clamping plate	Latch
20.102.0500.---	high	Standard
20.103.0500.---	flat	Standard

BB lock

Warded lock with 2 keys

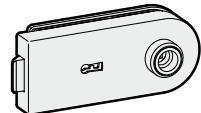

Part#	Clamping plate	Latch
20.104.0500.---	high	Standard
20.105.0500.---	flat	Standard

PC lock

Prepared for profile cylinder

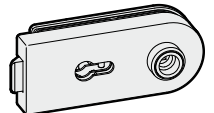

Part#	Clamping plate	Latch
20.106.0500.---	high	Standard
20.107.0500.---	flat	Standard

WC lock

Lock with control knob on lock side and "red-white" indicator
Glass thickness: 8 mm,
Frame rebate depth: 24 mm

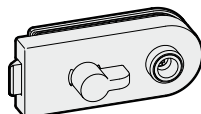

Part#	Clamping plate	Latch	Design
20.112.0411.---	high	Standard	DIN left, inwards
20.112.0421.---	high	Standard	DIN right, inwards
20.113.0411.---	flat	Standard	DIN left, inwards
20.113.0421.---	flat	Standard	DIN right, inwards

Note:

For a definition of the DIN and opening direction of WC locks with a control knob, please refer to page 16.

WC lock

Lock with control knob on clamping plate side and "red-white" indicator
Glass thickness: 8 mm,
Frame rebate depth: 24 mm

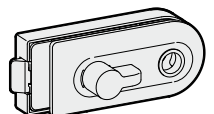

Part#	Clamping plate	Latch	Design
20.114.0412.---	high	Standard	DIN left, outwards
20.114.0422.---	high	Standard	DIN right, outwards
20.115.0412.---	flat	Standard	DIN left, outwards
20.115.0422.---	flat	Standard	DIN right, outwards

Note:

For a definition of the DIN and opening direction of WC locks with a control knob, please refer to page 16.

GK striker box, large

Striker box for double-sash doors

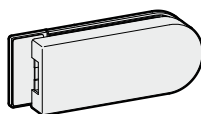

Part#	Clamping plate
20.146.0500.---	high
20.147.0500.---	flat

GK striker box, small

Striker box for double-sash doors

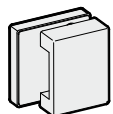

Part#	Clamping plate
20.149.0500.---	flat

Note:

Please pay attention to glass processing on page 63.

STUDIO locks with OBJEKT hinges

Scope of delivery:

- 1 lock with handle guide of your choice
- 2 OBJEKT hinges with sleeves

Available finishes:

- .112 Al E4/C-0 silver anodized
- .137 Al E4/C-31 stainless steel anodized
- .198 Al stainless steel finish

- Use in commercial properties
- Door weight: max. 60 kg
- Glass thickness: 8 (10) mm
- Frame rebate depth: 24 (26) mm



UV lock

Latch lock, non-locking
handle positioned on the reverse side

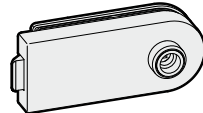

Part#	Clamping plate	Latch
20.100.1500.---	high	Standard
20.101.1500.---	flat	Standard

UV lock

Latch lock, non-locking
handle positioned at front

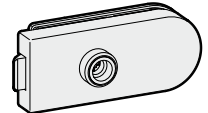

Part#	Clamping plate	Latch
20.102.1500.---	high	Standard
20.103.1500.---	flat	Standard

BB lock

Warded lock with 2 keys



Part#	Clamping plate	Latch
20.104.1500.---	high	Standard
20.105.1500.---	flat	Standard

PC lock

Prepared for profile cylinder

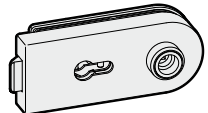

Part#	Clamping plate	Latch
20.106.1500.---	high	Standard
20.107.1500.---	flat	Standard

WC lock

Lock with control knob on lock side
and "red-white" indicator

Glass thickness: 8 mm,
Frame rebate depth: 24 mm

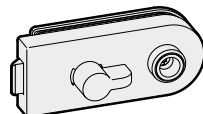

Part#	Clamping plate	Latch	Design
20.112.1411.---	high	Standard	DIN left, inwards
20.112.1421.---	high	Standard	DIN right, inwards
20.113.1411.---	flat	Standard	DIN left, inwards
20.113.1421.---	flat	Standard	DIN right, inwards

Note:

For a definition of the DIN and opening direction of WC locks with a control knob, please refer to page 16.

WC lock

Lock with control knob on clamping plate side
and "red-white" indicator

Glass thickness: 8 mm,
Frame rebate depth: 24 mm

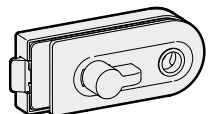

Part#	Clamping plate	Latch	Design
20.114.1412.---	high	Standard	DIN left, outwards
20.114.1422.---	high	Standard	DIN right, outwards
20.115.1412.---	flat	Standard	DIN left, outwards
20.115.1422.---	flat	Standard	DIN right, outwards

Note:

For a definition of the DIN and opening direction of WC locks with a control knob, please refer to page 16.

GK striker box, large

Striker box for double-sash doors

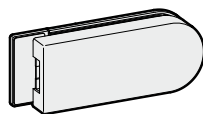

Part#	Clamping plate
20.146.1500.---	high
20.147.1500.---	flat

GK striker box, small

Striker box for double-sash doors

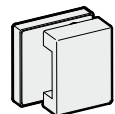

Part#	Clamping plate
20.149.1500.---	flat

Note:

Please pay attention to glass processing on page 63.

STUDIO locks with OBJEKT hinges with fixing plate

Scope of delivery:

- 1 lock with handle guide of your choice
- 2 OBJEKT hinges with fixing plate

Available finishes:

- .112 Al E4/C-0 silver anodized
- .137 Al E4/C-31 stainless steel anodized
- .198 Al stainless steel finish

- Use in commercial properties
- Door weight: max. 50 kg with 500.000 closing cycles
max. 65 kg with 200.000 closing cycles
- Glass thickness: 8 (10) mm



UV lock

Latch lock, non-locking
handle positioned on the reverse side

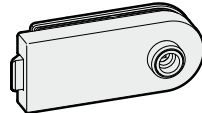

Part#	Clamping plate	Latch
20.100.2500.---	high	Standard
20.101.2500.---	flat	Standard

UV lock

Latch lock, non-locking
handle positioned at front

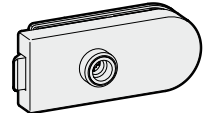

Part#	Clamping plate	Latch
20.102.2500.---	high	Standard
20.103.2500.---	flat	Standard

BB lock

Warded lock with 2 keys



Part#	Clamping plate	Latch
20.104.2500.---	high	Standard
20.105.2500.---	flat	Standard

PC lock

Prepared for profile cylinder

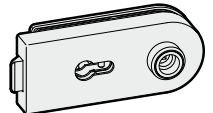

Part#	Clamping plate	Latch
20.106.2500.---	high	Standard
20.107.2500.---	flat	Standard

WC lock

Lock with control knob on lock side
and "red-white" indicator
Glass thickness: 8 mm

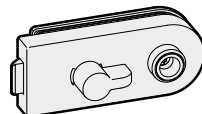

Part#	Clamping plate	Latch	Design
20.112.2411.---	high	Standard	DIN left, inwards
20.112.2421.---	high	Standard	DIN right, inwards
20.113.2411.---	flat	Standard	DIN left, inwards
20.113.2421.---	flat	Standard	DIN right, inwards

WC lock

Lock with control knob on clamping plate side
and "red-white" indicator
Glass thickness: 8 mm

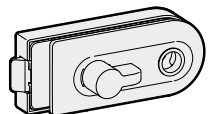

Part#	Clamping plate	Latch	Design
20.114.2412.---	high	Standard	DIN left, outwards
20.114.2422.---	high	Standard	DIN right, outwards
20.115.2412.---	flat	Standard	DIN left, outwards
20.115.2422.---	flat	Standard	DIN right, outwards

Note:

For a definition of the DIN and opening direction of WC locks with a control knob, please refer to page 16.

Note:

For a definition of the DIN and opening direction of WC locks with a control knob, please refer to page 16.

GK striker box, large

Striker box for double-sash doors

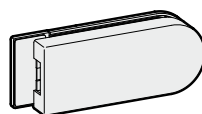

Part#	Clamping plate
20.146.2500.---	high
20.147.2500.---	flat

GK striker box, small

Striker box for double-sash doors

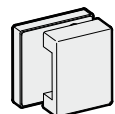

Part#	Clamping plate
20.149.2500.---	flat

Note:

Please pay attention to glass processing on page 63.

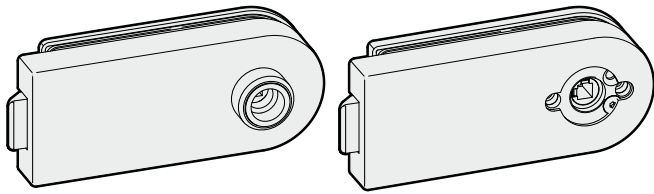

With handle guide

For door handles with roses

UV lock

- Latch lock, non-locking
- **Handle positioned at on the reverse siderear**
- Glass thickness: 8 (10) mm
- Frame rebate depth: 24 (26) mm

With handle guide

Part#	Clamping plate	Latch
20.200.0500.---	high	Standard
20.201.0500.---	flat	Standard
20.200.6500.---	high	Magnet
20.201.6500.---	flat	Magnet

For door handles with roses

Part#	Clamping plate	Latch
20.225.0500.---	flat	Standard
20.225.6500.---	flat	Magnet

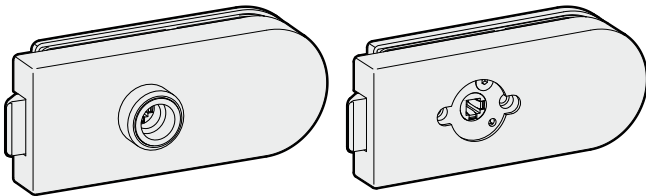

With handle guide

For door handles with roses

UV lock

- Latch lock, non-locking
- **Handle positioned at front**
- Glass thickness: 8 (10) mm
- Frame rebate depth: 24 (26) mm

With handle guide

Part#	Clamping plate	Latch
20.202.0500.---	high	Standard
20.203.0500.---	flat	Standard
20.202.6500.---	high	Magnet
20.203.6500.---	flat	Magnet

For door handles with roses

Part#	Clamping plate	Latch
20.227.0500.---	flat	Standard
20.227.6500.---	flat	Magnet

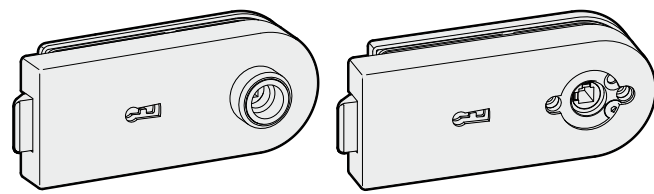

With handle guide

For door handles with roses

BB lock

- Warded lock with 2 keys
- Glass thickness: 8 (10) mm
- Frame rebate depth: 24 (26) mm

With handle guide

Part#	Clamping plate	Latch
20.204.0500.---	high	Standard
20.205.0500.---	flat	Standard

With handle guide
lockable, no projection

Part#	Clamping plate	Latch
20.204.5500.---	high	Standard
20.205.5500.---	flat	Standard
20.204.6500.---	high	Magnet
20.205.6500.---	flat	Magnet

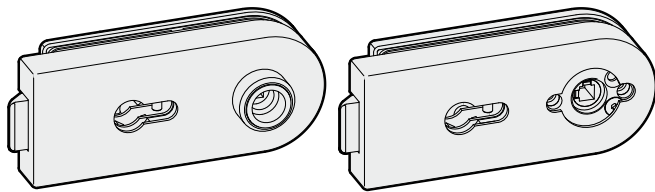

With handle guide

For door handles with roses

For door handles with roses

Part#	Clamping plate	Latch
20.235.0500.---	flat	Standard

For door handles with roses
lockable, no projection

Part#	Clamping plate	Latch
20.235.5500.---	flat	Standard
20.235.6500.---	flat	Magnet

PC lock

- Prepared for profile cylinder
- Glass thickness: 8 (10) mm
- Frame rebate depth: 24 (26) mm

With handle guide

Part#	Clamping plate	Latch
20.206.0500.---	high	Standard
20.207.0500.---	flat	Standard

With handle guide
lockable, no projection

Part#	Clamping plate	Latch
20.206.5500.---	high	Standard
20.207.5500.---	flat	Standard
20.206.6500.---	high	Magnet
20.207.6500.---	flat	Magnet

For door handles with roses

Part#	Clamping plate	Latch
20.245.0500.---	flat	Standard

For door handles with roses
lockable, no projection

Part#	Clamping plate	Latch
20.245.5500.---	flat	Standard
20.245.6500.---	flat	Magnet

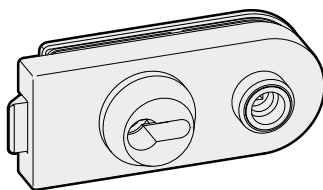

With handle guide

PC lock with PC rose

- Prepared for profile cylinder
- With PC rose for flush fit of a 63 mm long profile cylinder according to DIN 18257
- Glass thickness: 8 (10) mm
- Frame rebate depth: 24 (26) mm

With handle guide

Part#	Clamping plate	Latch
20.210.0500.---	high	Standard

With handle guide
lockable, no projection

Part#	Clamping plate	Latch
20.210.5500.---	high	Standard
20.210.6500.---	high	Magnet

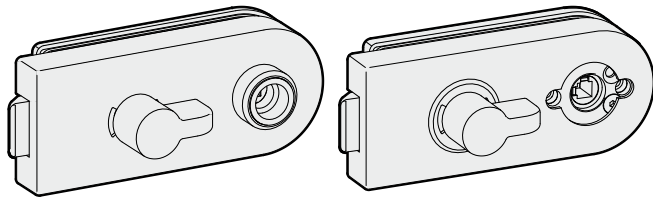

With handle guide

For door handles with roses

Illustration DIN right, inwards

WC lock

- Lock with control knob on lock side and “red-white” indicator
- Glass thickness: 8 mm
- Frame rebate depth: 24 mm

With handle guide

Part#	Clamping plate	Latch	Design
20.220.0411.---	high	Standard	DIN left, inwards
20.220.0421.---	high	Standard	DIN right, inwards
20.221.0411.---	flat	Standard	DIN left, inwards
20.221.0421.---	flat	Standard	DIN right, inwards

With handle guide
lockable, no projection

Part#	Clamping plate	Latch	Design
20.220.5411.---	high	Standard	DIN left, inwards
20.220.5421.---	high	Standard	DIN right, inwards
20.221.5411.---	flat	Standard	DIN left, inwards
20.221.5421.---	flat	Standard	DIN right, inwards
20.220.6411.---	high	Magnet	DIN left, inwards
20.220.6421.---	high	Magnet	DIN right, inwards
20.221.6411.---	flat	Magnet	DIN left, inwards
20.221.6421.---	flat	Magnet	DIN right, inwards

For door handles with roses

Part#	Clamping plate	Latch	Design
20.277.0411.---	flat	Standard	DIN left, inwards
20.277.0421.---	flat	Standard	DIN right, inwards

For door handles with roses

Part#	Clamping plate	Latch	Design
20.277.5411.---	flat	Standard	DIN left, inwards
20.277.5421.---	flat	Standard	DIN right, inwards
20.277.6411.---	flat	Magnet	DIN left, inwards
20.277.6421.---	flat	Magnet	DIN right, inwards

Definition of the DIN and opening direction of WC locks with a control knob

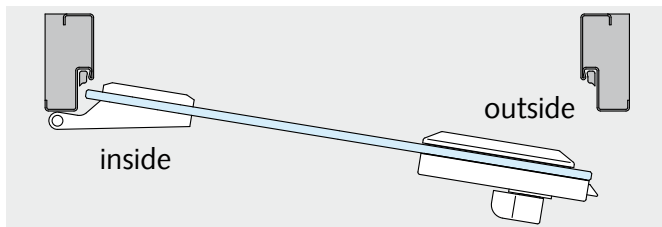

Control knob on lock side (DIN left inwards)

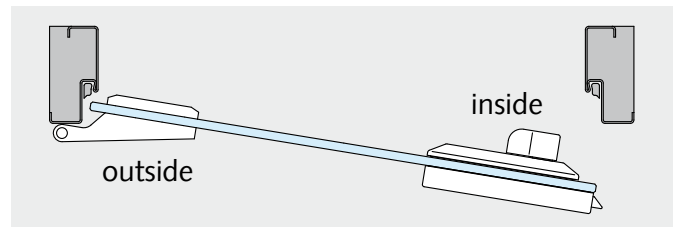

Control knob on clamping plate side (DIN left outwards)

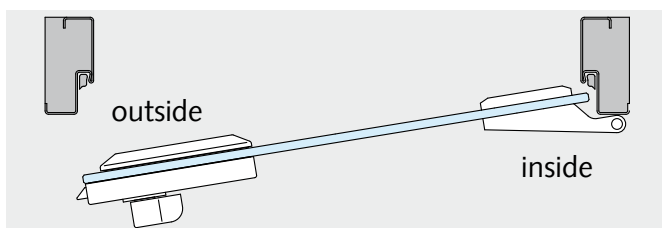

Control knob on lock side (DIN right inwards)

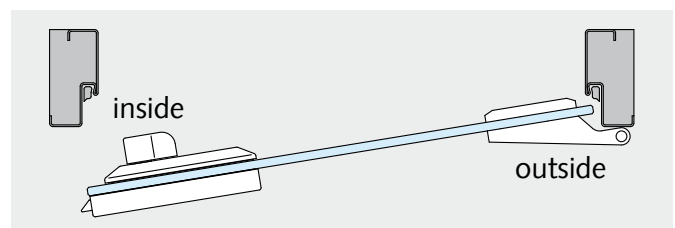

Control knob on clamping plate side (DIN right outwards)

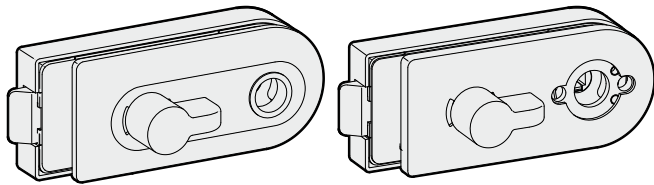

With handle guide

For door handles with roses

Illustration DIN left, outwards

WC lock

- Lock with control knob on clamping plate side and “red-white” indicator
- Glass thickness: 8 mm
- Frame rebate depth: 24 mm

With handle guide

Part#	Clamping plate	Latch	Design
20.222.0412.---	high	Standard	DIN left, outwards
20.222.0422.---	high	Standard	DIN right, outwards
20.223.0412.---	flat	Standard	DIN left, outwards
20.223.0422.---	flat	Standard	DIN right, outwards

With handle guide
lockable, no projection

Part#	Clamping plate	Latch	Design
20.222.5412.---	high	Standard	DIN left, outwards
20.222.5422.---	high	Standard	DIN right, outwards
20.223.5412.---	flat	Standard	DIN left, outwards
20.223.5422.---	flat	Standard	DIN right, outwards
20.222.6412.---	high	Magnet	DIN left, outwards
20.222.6422.---	high	Magnet	DIN right, outwards
20.223.6412.---	flat	Magnet	DIN left, outwards
20.223.6422.---	flat	Magnet	DIN right, outwards

For door handles with roses

Part#	Clamping plate	Latch	Design
20.287.0412.---	flat	Standard	DIN left, outwards
20.287.0422.---	flat	Standard	DIN right, outwards

For door handles with roses
lockable, no projection

Part#	Clamping plate	Latch	Design
20.287.5412.---	flat	Standard	DIN left, outwards
20.287.5422.---	flat	Standard	DIN right, outwards
20.287.6412.---	flat	Magnet	DIN left, outwards
20.287.6422.---	flat	Magnet	DIN right, outwards

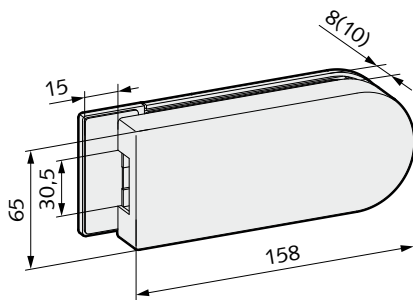

GK striker box, large

- Striker box for double-sash doors
- Glass thickness: 8 (10) mm

Part#	Clamping plate
20.254.0500.---	high
20.255.0500.---	flat

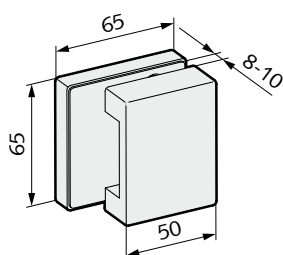

GK Striker box, small

- Striker box for double-sash doors
- Glass thickness: 8 (10) mm

Part#	Clamping plate
20.257.0500.---	flat

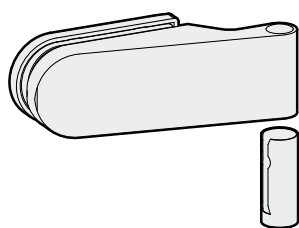

Hinge with sleeve

Part#	Glass thickness	Frame rebate depth
20.300.0500.---	8 (10) mm	24 (26) mm

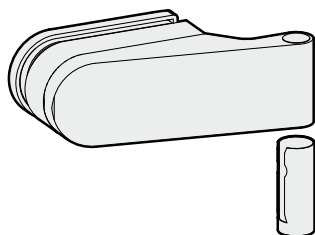

Hinge with sleeve up to 45 mm frame rebate depth

Part#	Glass thickness	Frame rebate depth
20.302.0401.---	8 mm	40 mm
20.304.0402.---	8 mm	26-45 mm
20.306.0901.---	10 mm	40 mm
20.308.0902.---	10 mm	26-45 mm

Note:
Please specify the exact frame rebate depth.

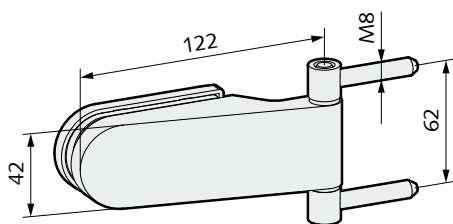

Hinge

- With frame parts for fastening to wooden block frames
- Suitable for door weights up to 35 kg

Part#	Glass thickness	Frame rebate depth
20.310.0500.---	8 (10) mm	24 (26) mm

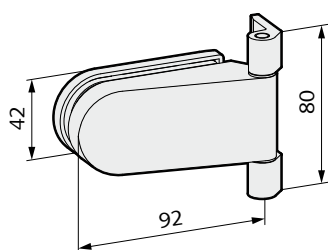

Hinge

- With frame parts for steel frames
- Can be screwed into place
- Suitable for door weights up to 35 kg

Part#	Glass thickness
20.312.0500.---	8 (10) mm

Note:
Please pay attention to glass processing on page 63.

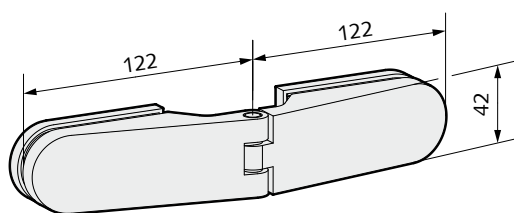

Hinge, glass-glass

- Hinge for installation on glass side parts
- Suitable for door weights up to 35 kg

Part#	Glass thickness
20.318.0500.---	8 (10) mm

Note:
Please pay attention to glass processing on page 63.

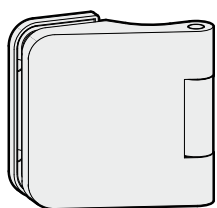

Hinge with sleeve

Part#	Glass thickness	Frame rebate depth
21.300.0500.---	8 (10) mm	24 (26) mm

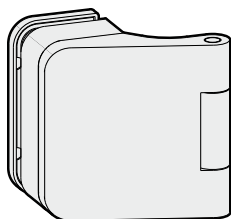

Hinge with sleeve up to 45 mm frame rebate depth

Part#	Glass thickness	Frame rebate depth
21.302.0401.---	8 mm	40 mm
21.304.0402.---	8 mm	26-45 mm
21.306.0901.---	10 mm	40 mm
21.308.0902.---	10 mm	26-45 mm

Note:

Please specify the exact frame rebate depth.

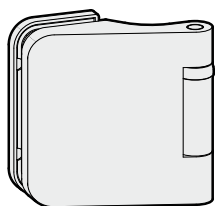

Hinge with ball bearing and sleeve

Part#	Design	Glass thickness	Frame rebate depth
21.310.0510.---	DIN left	8 (10) mm	24 (26) mm
21.310.0520.---	DIN right	8 (10) mm	24 (26) mm

Illustration DIN right

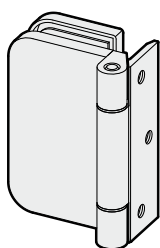

Hinge with fixing plate

- For non-rebated door frames
- Door weight: max. 50 kg for 500,000 closing cycles
max. 65 kg for 200,000 closing cycles

Part#	Glass thickness
21.320.0500.---	8-10 mm



STUDIO ALEA

Creative ideas.

Elegant and timeless.

Technical data:

Glass:	8 and 10 mm toughened safety glass (12 mm on request) 8,76 and 10,76 mm laminated safety glass of 2x toughened safety glass
Door weight:	max. 47 kg (hinges for private sector) max. 60 kg (hinges for commercial properties)
Door width:	max. 1.000 mm
Frame rebate depth:	24 to 45 mm possible
Lock:	analogous DIN EN 12209 tested with 1,5 million closing cycles (specification: 500.000 closing cycles)
Corrosion protection:	analogous DIN EN 1670 / Class 3
Deadbolt projection:	20 mm (1-turn)
Hinge:	analogous DIN EN 1935 tested with 200.000 closing cycles (private sector) and 500,000 closing cycles (commercial property)
Use:	Installation in frames according to DIN 18101/18111

Further information:

Glass processing	Page 60–63
Door weights	Page 64–65
Installation details	Page 66–72

Features:

- Locks for use in residential homes and commercial properties
- Hinges optionally for residential homes or commercial properties
- Lock and hinge in a square design
- Lock with standard and noise-reducing latch
- Lock can be used on the left/right
- Lock optionally with high or flat clamping plate
- Lock optionally with magnetic latch too
- Lock optionally as lockable, no projection
- Lock with low-wear polyisocyanate springs
- Optimum hold for the square spindle thanks to the clamp follower
- Progressive adjustment of the door handle resistance
- For standard handles with 18 mm shoulder guide, optionally also with handle roses
- With 10 mm toughened safety glass and 24 mm frame rebate depth, the latch head can be supplied machined

Materials and finishes:

Aluminium	E4/C-0 silver anodized	112
	E4/C-31 stainless steel anodized	137
	Polished chrome	174
	Stainless steel finish	198
	in special colour anodized	199
	RAL 9010 pure white powder coated	250
	RAL powder coated	295

UV lock
Handle position
front

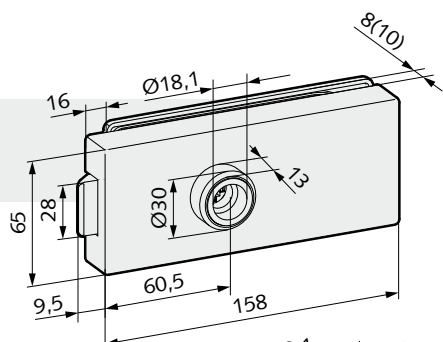

PC lock
prepared for
profile cylinder (PC)

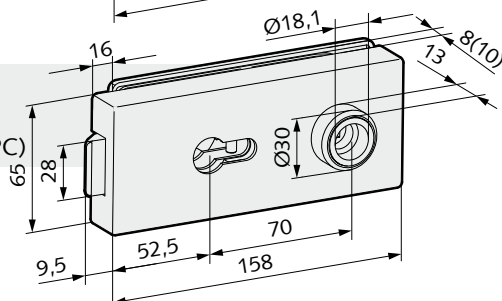

Total thickness: Lock with high clamping plate 45 (47) mm
Lock with flat clamping plate 39 (41) mm

Hinge with sleeve
for 24 mm frame rebate depth
(residential homes)

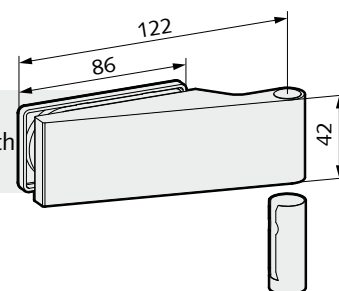

Hinge with sleeve
for 24 mm frame rebate depth
(commercial properties)

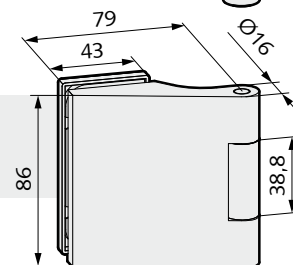

Hinge with fixing plate
for non-rebated door frames
(commercial properties)

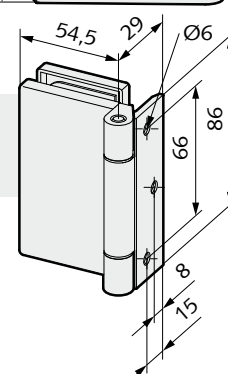

How to choose the right product

The hardware can be ordered as sets or individual components.

Sets (lock **with** hinges) Page 23-25
 Individual components (lock **or** hinges) Page 26-31

We have compiled explanations of the respective tables on the basis of the example "Individual components/PC lock".

Please use the necessary order numbers from this table.

High clamping plate



Flat clamping plate



The locks are optionally available with a high or flat clamping plate.

PC lock

- prepared for profile cylinder
- Glass thickness: 8 (10) mm
- Frame rebate depth: 24 (26) mm

With handle guide



With handle guide

Part#	Clamping plate	Latch
20.606.0500.---	high	Standard
20.607.0500.---	flat	Standard

The locks can optionally be supplied with a handle guide or prepared for door handles with roses.

with handle guide
lockable, no projection

Part#	Clamping plate	Latch
20.606.5500.---	high	Standard
20.607.5500.---	flat	Standard
20.606.6500.---	high	Magnet
20.607.6500.---	flat	Magnet

For door handles with roses



For door handles with roses

Part#	Clamping plate	Latch
20.645.0500.---	flat	Standard

for door handles with roses
lockable, no projection

Part#	Clamping plate	Latch
20.645.5500.---	flat	Standard
20.645.6500.---	flat	Magnet

Lockable, no projection

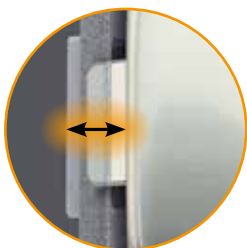

For use in narrow frame profiles
(only 10mm depth needed)

Standard latch

Noise-reducing latch

Magnetic latch



With the "Standard" design, you will receive a lock with fitted standard latch and an enclosed, exchangeable noise-reducing latch. With the "Magnet" design, you will receive a lock with a magnetic latch. A magnetic insert and magnetic clips for the frame are also available (see page 58).

STUDIO locks with STUDIO hinges

Scope of delivery:

- 1 lock with handle guide of your choice
- 2 STUDIO hinges with sleeves

Available finishes:

- .112 Al E4/C-0 silver anodized
- .137 Al E4/C-31 stainless steel anodized
- .198 Al stainless steel finish

- Use in residential homes
- Door weight: max. 47 kg
- Glass thickness: 8 (10) mm
- Frame rebate depth: 24 (26) mm



UV lock

Latch lock, non-locking
handle positioned on the reverse side

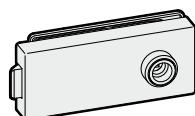

Part#	Clamping plate	Latch
20.500.0500.---	high	Standard
20.501.0500.---	flat	Standard

UV lock

Latch lock, non-locking
handle positioned at front

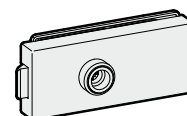

Part#	Clamping plate	Latch
20.502.0500.---	high	Standard
20.503.0500.---	flat	Standard

BB lock

Warded lock with 2 keys

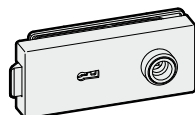

Part#	Clamping plate	Latch
20.504.0500.---	high	Standard
20.505.0500.---	flat	Standard

PC lock

Prepared for profile cylinder

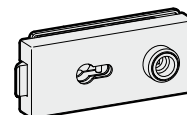

Part#	Clamping plate	Latch
20.506.0500.---	high	Standard
20.507.0500.---	flat	Standard

WC lock

Lock with control knob on lock side
and "red-white" indicator

Glass thickness: 8 mm,
Frame rebate depth: 24 mm

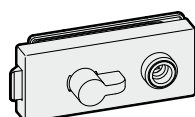

Part#	Clamping plate	Latch	Design
20.512.0411.---	high	Standard	DIN left, inwards
20.512.0421.---	high	Standard	DIN right, inwards
20.513.0411.---	flat	Standard	DIN left, inwards
20.513.0421.---	flat	Standard	DIN right, inwards

Note:

For a definition of the DIN and opening direction of WC locks with a control knob, please refer to page 28.

GK striker box, large

Striker box for double-sash doors

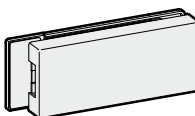

Part#	Clamping plate
20.546.0500.---	high
20.547.0500.---	flat

WC lock

Lock with control knob on clamping plate side
and "red-white" indicator

Glass thickness: 8 mm,
Frame rebate depth: 24 mm

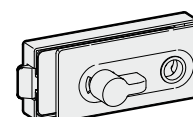

Part#	Clamping plate	Latch	Design
20.514.0412.---	high	Standard	DIN left, outwards
20.514.0422.---	high	Standard	DIN right, outwards
20.515.0412.---	flat	Standard	DIN left, outwards
20.515.0422.---	flat	Standard	DIN right, outwards

Note:

For a definition of the DIN and opening direction of WC locks with a control knob, please refer to page 28.

GK striker box, small

Striker box for double-sash doors

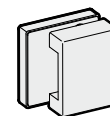

Part#	Clamping plate
20.549.0500.---	flat

Note:

Please pay attention to glass processing on page 63.

STUDIO locks with OBJEKT hinges

Scope of delivery:

- 1 lock with handle guide of your choice
- 2 OBJEKT hinges with sleeves

Available finishes:

- .112 Al E4/C-0 silver anodized
- .137 Al E4/C-31 stainless steel anodized
- .198 Al stainless steel finish

- Use in commercial properties
- Door weight: max. 60 kg
- Glass thickness: 8 (10) mm
- Frame rebate depth: 24 (26) mm



UV lock

Latch lock, non-locking handle positioned on the reverse side

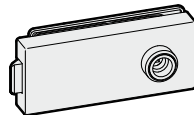

Part#	Clamping plate	Latch
20.500.1500.---	high	Standard
20.501.1500.---	flat	Standard

UV lock

Latch lock, non-locking handle positioned at front

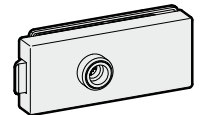

Part#	Clamping plate	Latch
20.502.1500.---	high	Standard
20.503.1500.---	flat	Standard

BB lock

Warded lock with 2 keys

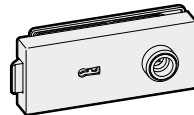

Part#	Clamping plate	Latch
20.504.1500.---	high	Standard
20.505.1500.---	flat	Standard

PC lock

Prepared for profile cylinder

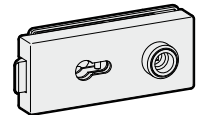

Part#	Clamping plate	Latch
20.506.1500.---	high	Standard
20.507.1500.---	flat	Standard

WC lock

Lock with control knob on lock side and "red-white" indicator
Glass thickness: 8 mm,
Frame rebate depth: 24 mm

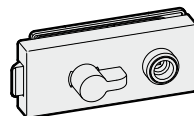

Part#	Clamping plate	Latch	Design
20.512.1411.---	high	Standard	DIN left, inwards
20.512.1421.---	high	Standard	DIN right, inwards
20.513.1411.---	flat	Standard	DIN left, inwards
20.513.1421.---	flat	Standard	DIN right, inwards

Note:

For a definition of the DIN and opening direction of WC locks with a control knob, please refer to page 28.

WC lock

Lock with control knob on clamping plate side and "red-white" indicator
Glass thickness: 8 mm,
Frame rebate depth: 24 mm

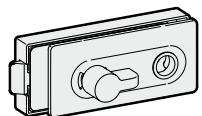

Part#	Clamping plate	Latch	Design
20.514.1412.---	high	Standard	DIN left, outwards
20.514.1422.---	high	Standard	DIN right, outwards
20.515.1412.---	flat	Standard	DIN left, outwards
20.515.1422.---	flat	Standard	DIN right, outwards

Note:

For a definition of the DIN and opening direction of WC locks with a control knob, please refer to page 28.

GK striker box, large

Striker box for double-sash doors

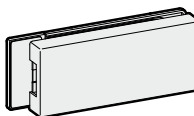

Part#	Clamping plate
20.546.1500.---	high
20.547.1500.---	flat

GK striker box, small

Striker box for double-sash doors

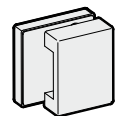

Part#	Clamping plate
20.549.1500.---	flat

Note:

Please pay attention to glass processing on page 63.

STUDIO locks with OBJEKT hinges with fixing plate

Scope of delivery:

- 1 lock with handle guide of your choice
- 2 OBJEKT hinges with fixing plate

Available finishes:

- .112 Al E4/C-0 silver anodized
- .137 Al E4/C-31 stainless steel anodized
- .198 Al stainless steel finish

- Use in commercial properties
- Door weight: max. 50 kg with 500.000 closing cycles
max. 65 kg with 200.000 closing cycles
- Glass thickness: 8 (10) mm

**UV lock**

Latch lock, non-locking
handle positioned on the reverse side

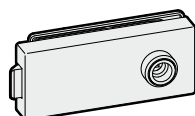

Part#	Clamping plate	Latch
20.500.2500.---	high	Standard
20.501.2500.---	flat	Standard

UV lock

Latch lock, non-locking
handle positioned at front

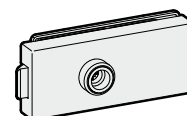

Part#	Clamping plate	Latch
20.502.2500.---	high	Standard
20.503.2500.---	flat	Standard

BB lock

Warded lock with 2 keys

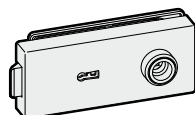

Part#	Clamping plate	Latch
20.504.2500.---	high	Standard
20.505.2500.---	flat	Standard

PC lock

Prepared for profile cylinder

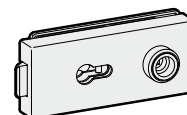

Part#	Clamping plate	Latch
20.506.2500.---	high	Standard
20.507.2500.---	flat	Standard

WC lock

Lock with control knob on lock side
and "red-white" indicator
Glass thickness: 8 mm

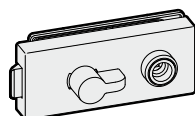

Part#	Clamping plate	Latch	Design
20.512.2411.---	high	Standard	DIN left, inwards
20.512.2421.---	high	Standard	DIN right, inwards
20.513.2411.---	flat	Standard	DIN left, inwards
20.513.2421.---	flat	Standard	DIN right, inwards

Note:

For a definition of the DIN and opening direction of WC locks with a control knob, please refer to page 28.

WC lock

Lock with control knob on clamping plate side
and "red-white" indicator
Glass thickness: 8 mm

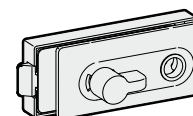

Part#	Clamping plate	Latch	Design
20.514.2412.---	high	Standard	DIN left, outwards
20.514.2422.---	high	Standard	DIN right, outwards
20.515.2412.---	flat	Standard	DIN left, outwards
20.515.2422.---	flat	Standard	DIN right, outwards

Note:

For a definition of the DIN and opening direction of WC locks with a control knob, please refer to page 28.

GK striker box, large

Striker box for double-sash doors

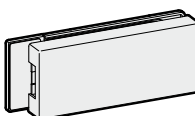

Part#	Clamping plate
20.546.2500.---	high
20.547.2500.---	flat

GK striker box, small

Striker box for double-sash doors

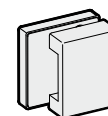

Part#	Clamping plate
20.549.2500.---	flat

Note:

Please pay attention to glass processing on page 63.

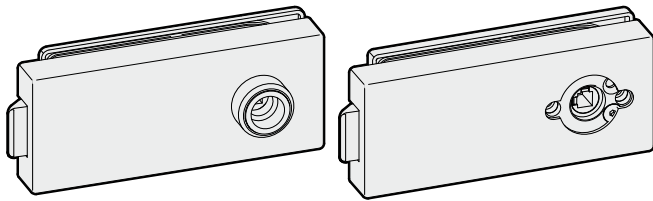

With handle guide

For door handles with roses

UV lock

- Latch lock, non-locking
- **Handle positioned on the reverse side**
- Glass thickness: 8 (10) mm
- Frame rebate depth: 24 (26) mm

With handle guide

Part#	Clamping plate	Latch
20.600.0500.---	high	Standard
20.601.0500.---	flat	Standard
20.600.6500.---	high	Magnet
20.601.6500.---	flat	Magnet

For door handles with roses

Part#	Clamping plate	Latch
20.625.0500.---	flat	Standard
20.625.6500.---	flat	Magnet

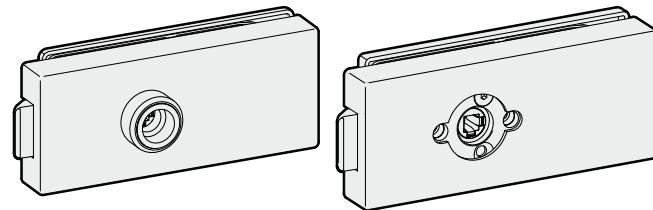

With handle guide

For door handles with roses

UV lock

- Latch lock, non-locking
- **Handle positioned at front**
- Glass thickness: 8 (10) mm
- Frame rebate depth: 24 (26) mm

With handle guide

Part#	Clamping plate	Latch
20.602.0500.---	high	Standard
20.603.0500.---	flat	Standard
20.602.6500.---	high	Magnet
20.603.6500.---	flat	Magnet

For door handles with roses

Part#	Clamping plate	Latch
20.627.0500.---	flat	Standard
20.627.6500.---	flat	Magnet

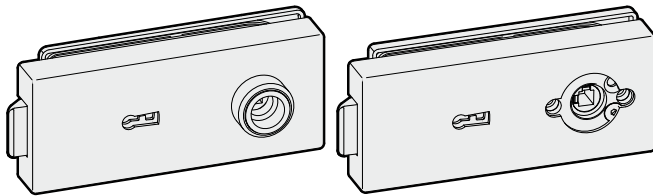

With handle guide

For door handles with roses

BB lock

- Warded lock with 2 keys
- Glass thickness: 8 (10) mm
- Frame rebate depth: 24 (26) mm

With handle guide

Part#	Clamping plate	Latch
20.604.0500.---	high	Standard
20.605.0500.---	flat	Standard

With handle guide
lockable, no projection

Part#	Clamping plate	Latch
20.604.5500.---	high	Standard
20.605.5500.---	flat	Standard
20.604.6500.---	high	Magnet
20.605.6500.---	flat	Magnet

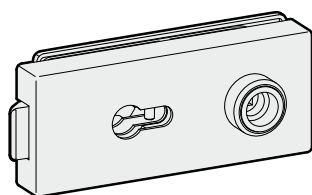

With handle guide

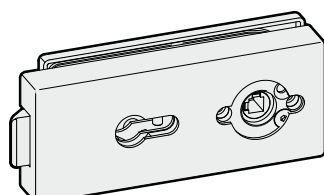

For door handles with roses

For door handles with roses

Part#	Clamping plate	Latch
20.635.0500.---	flat	Standard

For door handles with roses
lockable, no projection

Part#	Clamping plate	Latch
20.635.5500.---	flat	Standard
20.635.6500.---	flat	Magnet

PC lock

- Prepared for profile cylinder
- Glass thickness: 8 (10) mm
- Frame rebate depth: 24 (26) mm

With handle guide

Part#	Clamping plate	Latch
20.606.0500.---	high	Standard
20.607.0500.---	flat	Standard

With handle guide
lockable, no projection

Part#	Clamping plate	Latch
20.606.5500.---	high	Standard
20.607.5500.---	flat	Standard
20.606.6500.---	high	Magnet
20.607.6500.---	flat	Magnet

For door handles with roses

Part#	Clamping plate	Latch
20.645.0500.---	flat	Standard

For door handles with roses
lockable, no projection

Part#	Clamping plate	Latch
20.645.5500.---	flat	Standard
20.645.6500.---	flat	Magnet

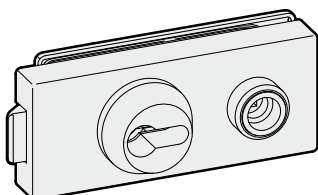

With handle guide

PC lock with PC rose

- Prepared for profile cylinder
- With PC rose for flush fit of a 63 mm long profile cylinder according to DIN 18257
- Glass thickness: 8 (10) mm
- Frame rebate depth: 24 (26) mm

With handle guide

Part#	Clamping plate	Latch
20.610.0500.---	high	Standard

With handle guide
lockable, no projection

Part#	Clamping plate	Latch
20.610.5500.---	high	Standard
20.610.6500.---	high	Magnet

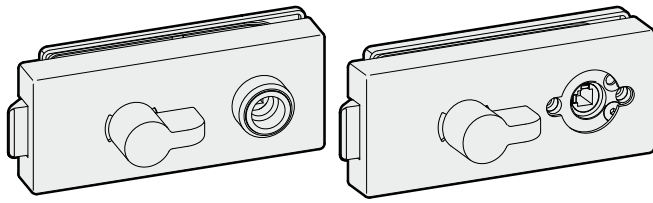

With handle guide

For door handles with roses

Illustration DIN right, inwards

WC lock

- Lock with control knob on lock side and “red-white” indicator
- Glass thickness: 8 mm
- Frame rebate depth: 24 mm

With handle guide

Part#	Clamping plate	Latch	Design
20.620.0411.---	high	Standard	DIN left, inwards
20.620.0421.---	high	Standard	DIN right, inwards
20.621.0411.---	flat	Standard	DIN left, inwards
20.621.0421.---	flat	Standard	DIN right, inwards

With handle guide
lockable, no projection

Part#	Clamping plate	Latch	Design
20.620.5411.---	high	Standard	DIN left, inwards
20.620.5421.---	high	Standard	DIN right, inwards
20.621.5411.---	flat	Standard	DIN left, inwards
20.621.5421.---	flat	Standard	DIN right, inwards
20.620.6411.---	high	Magnet	DIN left, inwards
20.620.6421.---	high	Magnet	DIN right, inwards
20.621.6411.---	flat	Magnet	DIN left, inwards
20.621.6421.---	flat	Magnet	DIN right, inwards

For door handles with roses

Part#	Clamping plate	Latch	Design
20.677.0411.---	flat	Standard	DIN left, inwards
20.677.0421.---	flat	Standard	DIN right, inwards

For door handles with roses
lockable, no projection

Part#	Clamping plate	Latch	Design
20.677.5411.---	flat	Standard	DIN left, inwards
20.677.5421.---	flat	Standard	DIN right, inwards
20.677.6411.---	flat	Magnet	DIN left, inwards
20.677.6421.---	flat	Magnet	DIN right, inwards

Definition of the DIN and opening direction of WC locks with a control knob

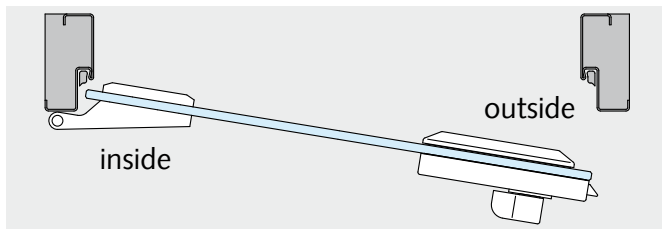

Control knob on lock side (DIN left inwards)

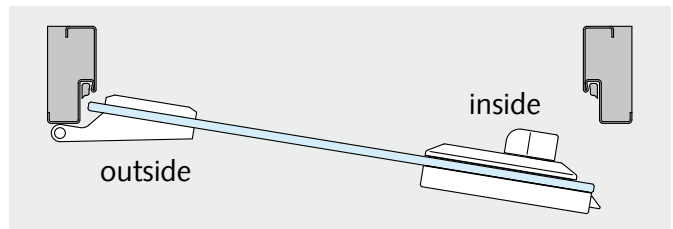

Control knob on clamping plate side (DIN left outwards)

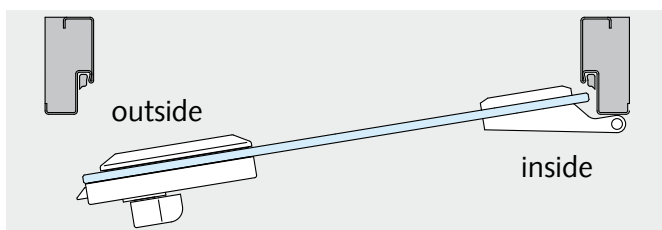

Control knob on lock side (DIN right inwards)

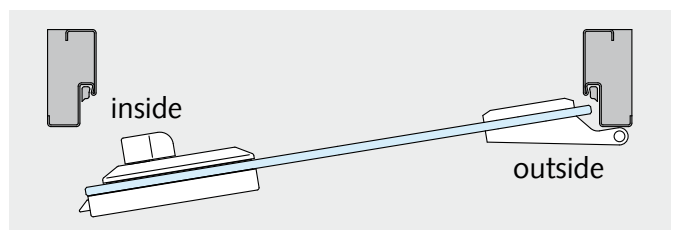

Control knob on clamping plate side (DIN right outwards)

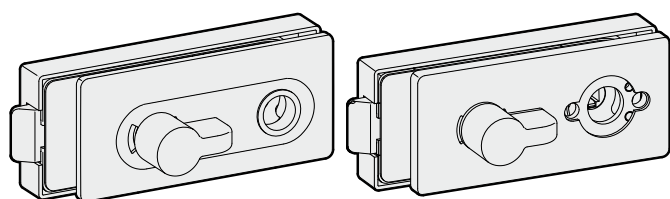

With handle guide

For door handles with roses

Illustration DIN left, outwards

WC lock

- Lock with control knob on clamping plate side and “red-white” indicator
- Glass thickness: 8 mm
- Frame rebate depth: 24 mm

With handle guide

Part#	Clamping plate	Latch	Design
20.622.0412.---	high	Standard	DIN left, outwards
20.622.0422.---	high	Standard	DIN right, outwards
20.623.0412.---	flat	Standard	DIN left, outwards
20.623.0422.---	flat	Standard	DIN right, outwards

With handle guide
lockable, no projection

Part#	Clamping plate	Latch	Design
20.622.5412.---	high	Standard	DIN left, outwards
20.622.5422.---	high	Standard	DIN right, outwards
20.623.5412.---	flat	Standard	DIN left, outwards
20.623.5422.---	flat	Standard	DIN right, outwards
20.622.6412.---	high	Magnet	DIN left, outwards
20.622.6422.---	high	Magnet	DIN right, outwards
20.623.6412.---	flat	Magnet	DIN left, outwards
20.623.6422.---	flat	Magnet	DIN right, outwards

For door handles with roses

Part#	Clamping plate	Latch	Design
20.687.0412.---	flat	Standard	DIN left, outwards
20.687.0422.---	flat	Standard	DIN right, outwards

For door handles with roses
lockable, no projection

Part#	Clamping plate	Latch	Design
20.687.5412.---	flat	Standard	DIN left, outwards
20.687.5422.---	flat	Standard	DIN right, outwards
20.687.6412.---	flat	Magnet	DIN left, outwards
20.687.6422.---	flat	Magnet	DIN right, outwards

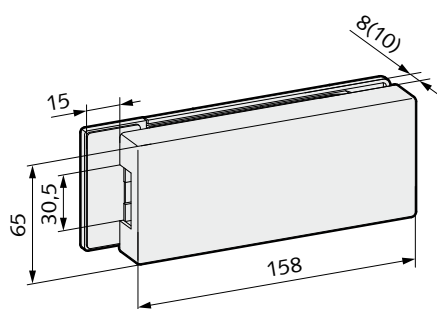

GK striker box, large

- Striker box for double-sash doors
- Glass thickness: 8 (10) mm

Part#	Clamping plate
20.654.0500.---	high
20.655.0500.---	flat

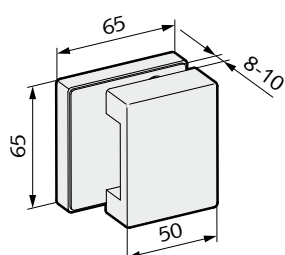

GK Striker box, small

- Striker box for double-sash doors
- Glass thickness: 8 (10) mm

Part#	Clamping plate
20.257.0500.---	flat

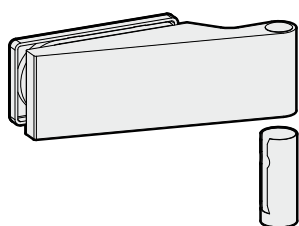

Hinge with sleeve

Part#	Glass thickness	Frame rebate depth
20.700.0500.---	8 (10) mm	24 (26) mm

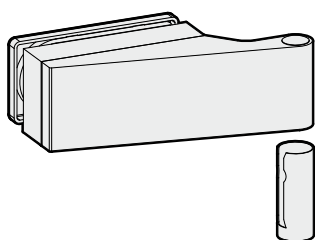

Hinge with sleeve up to 45 mm frame rebate depth

Part#	Glass thickness	Frame rebate depth
20.702.0401.---	8 mm	40 mm
20.704.0402.---	8 mm	26-45 mm
20.706.0901.---	10 mm	40 mm
20.708.0902.---	10 mm	26-45 mm

Note:

Please specify the exact frame rebate depth.

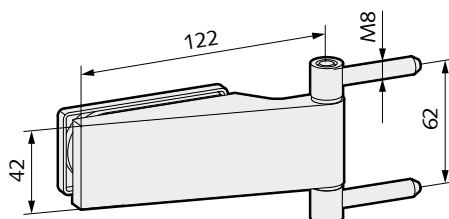

Hinge

- With frame parts for fastening to wooden block frames
- Suitable for door weights up to 35 kg

Part#	Glass thickness	Frame rebate depth
20.710.0500.---	8 (10) mm	24 (26) mm

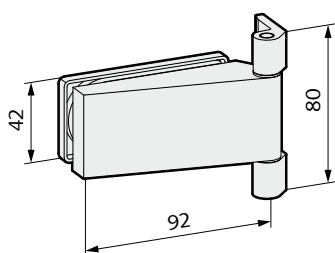

Hinge

- With frame parts for steel frames
- Can be screwed into place
- Suitable for door weights up to 35 kg

Part#	Glass thickness
20.712.0500.---	8 (10) mm

Note:

Please pay attention to glass processing on page 63.

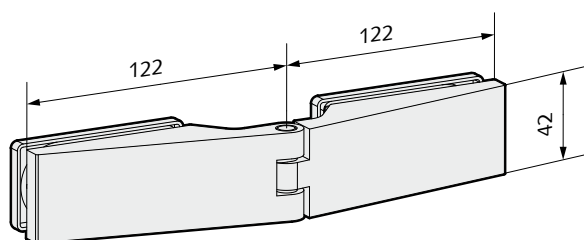

Hinge, glass-glass

- Hinge for installation on glass side parts
- Suitable for door weights up to 35 kg

Part#	Glass thickness
20.718.0500.---	8 (10) mm

Note:

Please pay attention to glass processing on page 63.

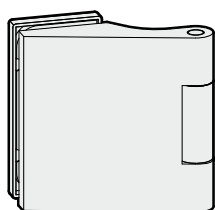

Hinge with sleeve

Part#	Glass thickness	Frame rebate depth
21.900.0500.---	8 (10) mm	24 (26) mm

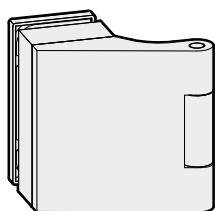

Hinge with sleeve up to 45 mm frame rebate depth

Part#	Glass thickness	Frame rebate depth
21.902.0401.---	8 mm	40 mm
21.904.0402.---	8 mm	26-45 mm
21.906.0901.---	10 mm	40 mm
21.908.0902.---	10 mm	26-45 mm

Note:

Please specify the exact frame rebate depth.

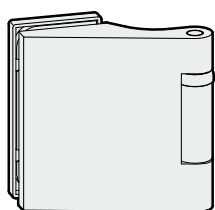
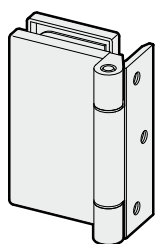

Illustration DIN right

Hinge with ball bearing and sleeve

Part#	Design	Glass thickness	Frame rebate depth
21.910.0510.---	DIN left	8 (10) mm	24 (26) mm
21.910.0520.---	DIN right	8 (10) mm	24 (26) mm



Hinge with fixing plate

- for non-rebated door frames
- Door weight: max. 50 kg for 500.000 closing cycles
max. 65 kg for 200.000 closing cycles

Part#	Glass thickness
21.920.0500.---	8-10 mm



STUDIO VENA

Make your mark.
Innovative and elegant design.

Technical data:

- Glass:**8 and 10mm toughened safety glass
(12 mm on request) 8,76 and 10,76mm laminated safety glass of 2x toughened safety glass
- Door weight:**max. 47 kg (hinges for private sector)
max. 60 kg (hinges for commercial properties)
- Door width:**max. 1.000mm
- Frame rebate depth:** .. 24 to 45mm possible
- Lock:**analogous DIN EN 12209
tested with 1,5 million closing cycles (specification: 500.000 closing cycles)
- Corrosion protection:**analogous DIN EN 1670 / Class 3
- Deadbolt projection:** ..20mm (1-turn)
- Hinge:**analogous DIN EN 1935 tested with 200.000 closing cycles (private sector) and 500.000 closing cycles (commercial property)
- Use:**Installation in frames according to DIN 18101/18111

Further information:

- Glass processingPage 60–63
- Door weightsPage 64–65
- Installation detailsPage 66–72

Features:

- Locks for use in residential homes and commercial properties
- Hinges optionally for residential homes or commercial properties
- Lock and hinge in an exclusive design
- Lock with standard and noise-reducing latch
- Lock can be used on the left/right
- Lock with flat clamping plate
- Lock optionally with magnetic latch too
- Lock optionally as lockable, no projection
- Lock with low-wear polyisocyanate springs
- Optimum hold for the square spindle thanks to the clamp follower
- Progressive adjustment of the door handle resistance
- For standard handles with 18mm shoulder guide
- With 10mm toughened safety glass and 24 mm frame rebate depth, the latch head can be supplied machined

Materials and finishes:

- Aluminium E4/C-0 silver anodized 112
- E4/C-31 stainless steel anodized 137
- Polished chrome 174
- Stainless steel finish 198
- in special colour anodized 199
- RAL 9010 pure white powder coated 250
- RAL powder coated 295

UV lock
Handle position front

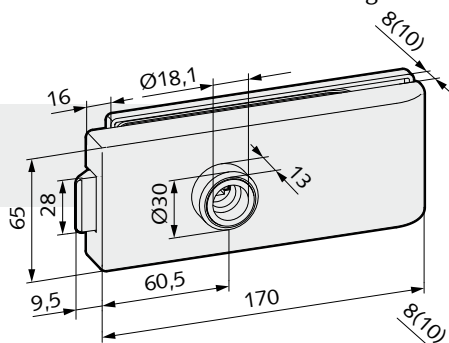

PC lock
prepared for profile cylinder (PC)

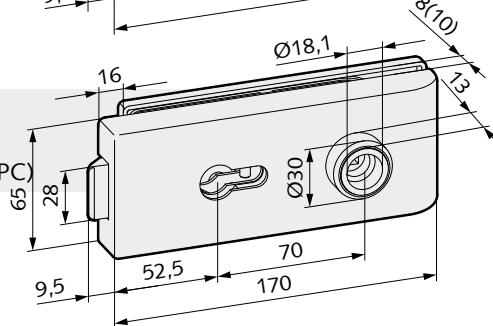

Total thickness: Lock with flat clamping plate 39 (41) mm

Hinge with sleeve
for 24 mm frame rebate depth (residential homes)

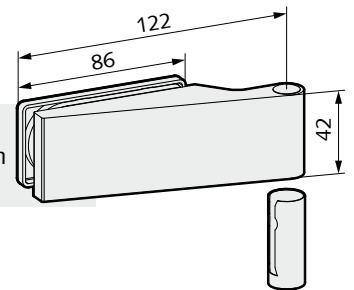

Hinge with sleeve
for 24 mm frame rebate depth (commercial properties)

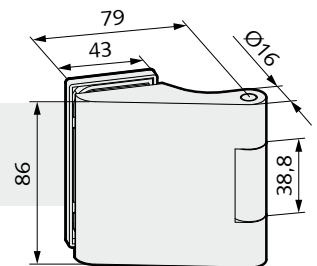

Hinge with fixing plate
for non-rebated door frames (commercial properties)

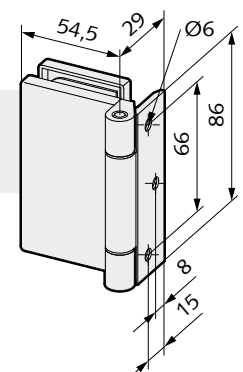

How to choose the right product

The hardware can be ordered as sets **or** individual components.

Sets (lock **with** hinges) Page 35-37
 Individual components (lock **or** hinges)Page 38-41

We have compiled explanations of the respective tables on the basis of the example "Individual components/PC lock".

Please use the necessary order numbers from this table.

Flat clamping plate



The locks are available with a flat clamping plate.

With handle guide



The locks are supplied with a handle guide.

PC lock

- Prepared for profile cylinder
- Glass thickness: 8 (10) mm
- Frame rebate depth: 24 (26) mm

With handle guide

Part#	Clamping plate	Latch
20.847.0500.---	flat	Standard

With handle guide
 lockable, no projection

Part#	Clamping plate	Latch
20.847.5500.---	flat	Standard
20.847.6500.---	flat	Magnet

Lockable, no projection

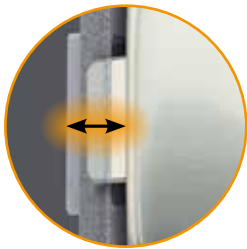

For use in narrow frame profiles
 (only 10mm depth needed)

Standard latch

Noise-reducing latch

Magnetic latch

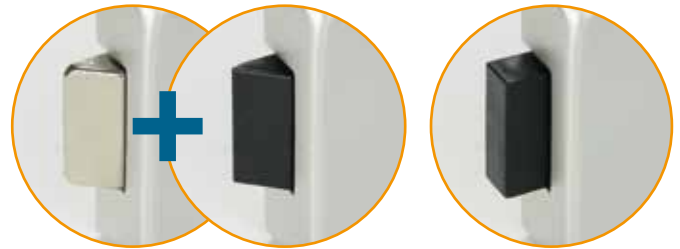

With the "Standard" design, you will receive a lock with fitted standard latch and an enclosed, exchangeable noise-reducing latch. With the "Magnet" design, you will receive a lock with a magnetic latch. A magnetic insert and magnetic clips for the frame are also available (see page 58).

STUDIO locks with STUDIO hinges

Scope of delivery:

- 1 lock with handle guide of your choice
- 2 STUDIO hinges with sleeves

Available finishes:

- .112 Al E4/C-0 silver anodized
- .137 Al E4/C-31 stainless steel anodized
- .198 Al stainless steel finish

- Use in residential homes
- Door weight: max. 47 kg
- Glass thickness: 8 (10) mm
- Frame rebate depth: 24 (26) mm



UV lock

Latch lock, non-locking handle positioned on the reverse side

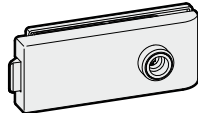

Part#	Clamping plate	Latch
20.801.0500.---	flat	Standard

UV lock

Latch lock, non-locking handle positioned at front

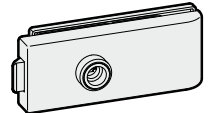

Part#	Clamping plate	Latch
20.803.0500.---	flat	Standard

BB lock

Warded lock with 2 keys

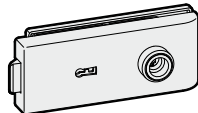

Part#	Clamping plate	Latch
20.805.0500.---	flat	Standard

PC lock

Prepared for profile cylinder

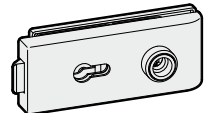

Part#	Clamping plate	Latch
20.807.0500.---	flat	Standard

GK striker box, small

Striker box for double-sash doors

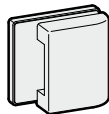

Part#	Clamping plate
20.809.0500.---	flat

Note:

Please pay attention to glass processing on page 63.

STUDIO locks with OBJEKT hinges

Scope of delivery:

- 1 lock with handle guide of your choice
- 2 OBJEKT hinges with sleeves

Available finishes:

- .112 Al E4/C-0 silver anodized
- .137 Al E4/C-31 stainless steel anodized
- .198 Al stainless steel finish

- Use in commercial properties
- Door weight: max. 60 kg
- Glass thickness: 8 (10) mm
- Frame rebate depth: 24 (26) mm



UV lock

Latch lock, non-locking handle positioned on the reverse side

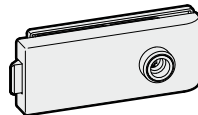

Part#	Clamping plate	Latch
20.801.1500.---	flat	Standard

UV lock

Latch lock, non-locking handle positioned at front

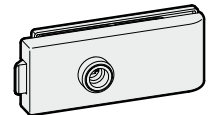

Part#	Clamping plate	Latch
20.803.1500.---	flat	Standard

BB lock

Warded lock with 2 keys



Part#	Clamping plate	Latch
20.805.1500.---	flat	Standard

PC lock

Prepared for profile cylinder

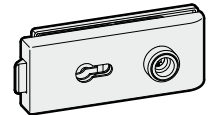

Part#	Clamping plate	Latch
20.807.1500.---	flat	Standard

GK striker box, small

Striker box for double-sash doors

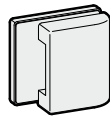

Part#	Clamping plate
20.809.1500.---	flat

Note:

Please pay attention to glass processing on page 63.

STUDIO locks with OBJEKT hinges with fixing plate

Scope of delivery:

- 1 lock with handle guide of your choice
- 2 OBJEKT hinges with fixing plate

Available finishes:

- .112 Al E4/C-0 silver anodized
- .137 Al E4/C-31 stainless steel anodized
- .198 Al stainless steel finish

- Use in commercial properties
- Door weight: max. 50kg with 500.000 closing cycles
max. 65kg with 200.000 closing cycles
- Glass thickness: 8 (10)mm



UV lock

Latch lock, non-locking handle positioned on the reverse side

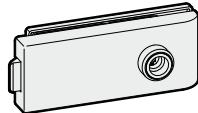

Part#	Clamping plate	Latch
20.801.2500.---	flat	Standard

UV lock

Latch lock, non-locking handle positioned at front

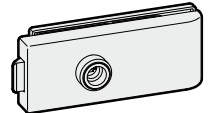

Part#	Clamping plate	Latch
20.803.2500.---	flat	Standard

BB lock

Warded lock with 2 keys

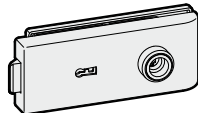

Part#	Clamping plate	Latch
20.805.2500.---	flat	Standard

PC lock

Prepared for profile cylinder

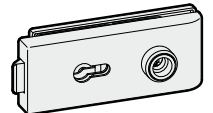

Part#	Clamping plate	Latch
20.807.2500.---	flat	Standard

GK striker box, small

Striker box for double-sash doors

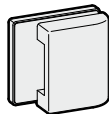

Part#	Clamping plate
20.809.2500.---	flat

Note:

Please pay attention to glass processing on page 63.

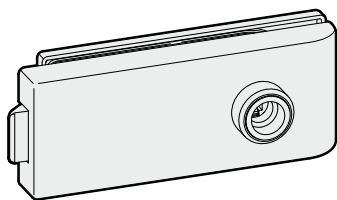

UV lock

- Latch lock, non-locking
- **Handle positioned on the reverse side**
- Glass thickness: 8 (10) mm
- Frame rebate depth: 24 (26) mm

With handle guide

Part#	Clamping plate	Latch
20.841.0500.---	flat	Standard
20.841.6500.---	flat	Magnet

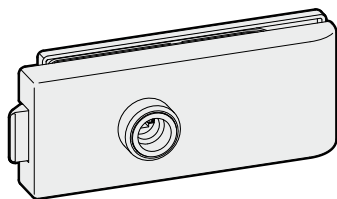

UV lock

- Latch lock, non-locking
- **Handle positioned at front**
- Glass thickness: 8 (10) mm
- Frame rebate depth: 24 (26) mm

With handle guide

Part#	Clamping plate	Latch
20.843.0500.---	flat	Standard
20.843.6500.---	flat	Magnet

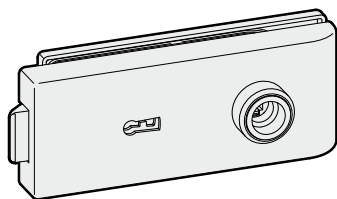

BB lock

- Warded lock with 2 keys
- Glass thickness: 8 (10) mm
- Frame rebate depth: 24 (26) mm

With handle guide

Part#	Clamping plate	Latch
20.845.0500.---	flat	Standard

With handle guide
lockable, no projection

Part#	Clamping plate	Latch
20.845.5500.---	flat	Standard
20.845.6500.---	flat	Magnet

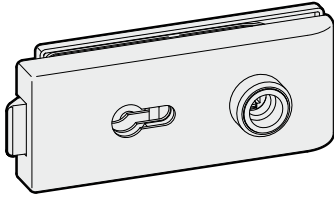

PC lock

- Prepared for profile cylinder
- Glass thickness: 8 (10) mm
- Frame rebate depth: 24 (26) mm

With handle guide

Part#	Clamping plate	Latch
20.847.0500.---	flat	Standard

With handle guide
lockable, no projection

Part#	Clamping plate	Latch
20.847.5500.---	flat	Standard
20.847.6500.---	flat	Magnet

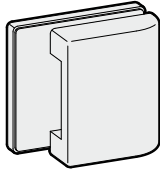

GK striker box, small

- Striker box for double-sash doors
- Glass thickness: 8 (10) mm

Part#	Clamping plate
20.849.0500.---	flat

Note:

Please pay attention to glass processing on page 63.

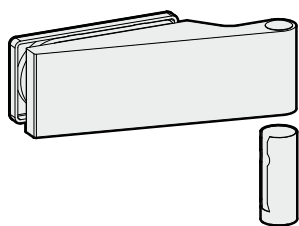

Hinge with sleeve

Part#	Glass thickness	Frame rebate depth
20.700.0500.---	8 (10) mm	24 (26) mm

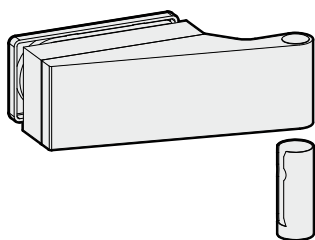

Hinge with sleeve up to 45 mm frame rebate depth

Part#	Glass thickness	Frame rebate depth
20.702.0401.---	8 mm	40 mm
20.704.0402.---	8 mm	26-45 mm
20.706.0901.---	10 mm	40 mm
20.708.0902.---	10 mm	26-45 mm

Note:
Please specify the exact frame rebate depth.

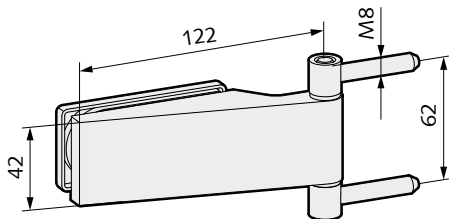

Hinge

- With frame parts for fastening to wooden block frames
- Suitable for door weights up to 35 kg

Part#	Glass thickness	Frame rebate depth
20.710.0500.---	8 (10) mm	24 (26) mm

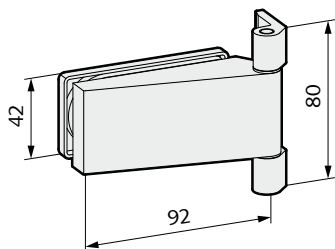

Hinge

- With frame parts for steel frames
- Can be screwed into place
- Suitable for door weights up to 35 kg

Part#	Glass thickness
20.712.0500.---	8 (10) mm

Note:
Please pay attention to glass processing on page 63.

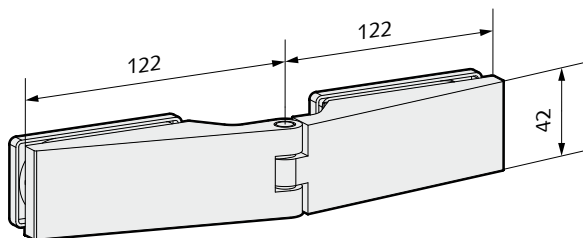

Hinge, glass-glass

- Hinge for installation on glass side parts
- Suitable for door weights up to 35 kg

Part#	Glass thickness
20.718.0500.---	8 (10) mm

Note:
Please pay attention to glass processing on page 63.

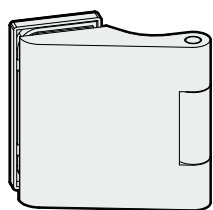

Hinge with sleeve

Part#	Glass thickness	Frame rebate depth
20.880.0500.---	8 (10) mm	24 (26) mm

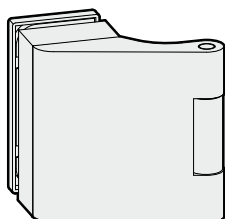

Hinge with sleeve up to 45 mm frame rebate depth

Part#	Glass thickness	Frame rebate depth
20.882.0401.---	8 mm	40 mm
20.884.0402.---	8 mm	26-45 mm
20.886.0901.---	10 mm	40 mm
20.888.0902.---	10 mm	26-45 mm

Note:

Please specify the exact frame rebate depth.

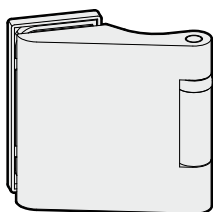

Hinge with ball bearing and sleeve

Part#	Design	Glass thickness	Frame rebate depth
20.890.0510.---	DIN left	8 (10) mm	24 (26) mm
20.890.0520.---	DIN right	8 (10) mm	24 (26) mm

Illustration DIN right

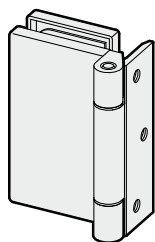

Hinge with fixing plate

- for non-rebated door frames
- Door weight: max. 50 kg for 500.000 closing cycles
max. 65 kg for 200.000 closing cycles

Part#	Glass thickness
21.920.0500.---	8-10 mm

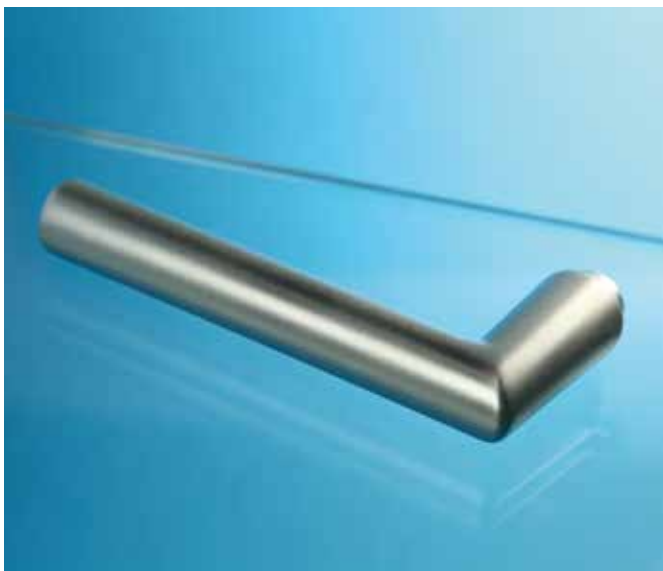

Accessories

Extensive choice of accessories – various options, more comfort.

Handles

Many possibilities with various shapes. Further models have been added to the extensive product range. Handle and lock – the perfect combination.

.....For details see pages 44-48

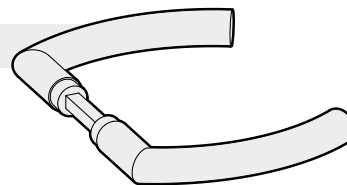

Handle and knob with no function

Exchangeable hardware with handle and free-turning knob (no function) can be used for locks with no shoulder guide.

.....For details see page 47

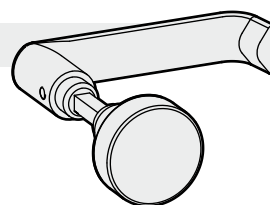

Frame parts

You will find a solution for every application. Frame parts for use in residential homes and commercial properties. The tested and practically proven load values are summarised in a neat table.

.....For details see pages 49-51

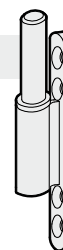

Door seals

More comfort through the use of door seals. The function of the "SCHALL-EX®" door seals. The seal profile is raised and lowered when the door opens and closes and protects against noise, cold and draughts.

.....For details see page 53

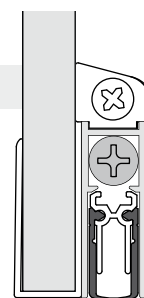

Door closers

Door closers close doors safely and automatically and are suitable for single action doors up to a max. leaf width of 1.100mm. The door closers have an infinitely variable retainer from 80° to 130° and an infinitely variable closing force according to DIN EN 1154.

.....For details see pages 54-55

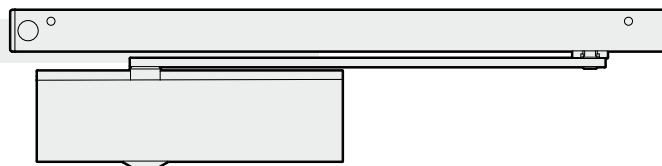

Corner hinges

The corner hinges with screw-on top and bottom pivots are suitable for glass doors between 8–12 mm thick and up to a max. door weight of 80kg. The corner hinges can be used on the left or right.

.....For details see page 57

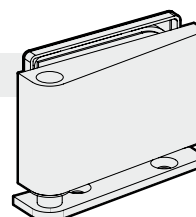

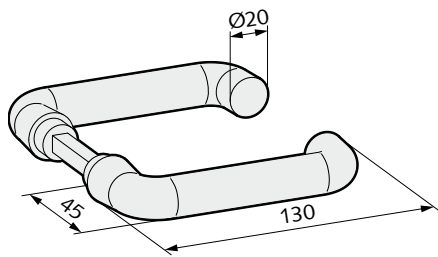

With shoulder guide

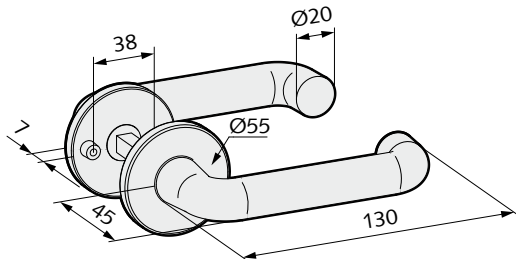

With handle roses

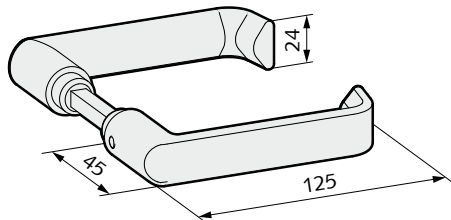

With shoulder guide

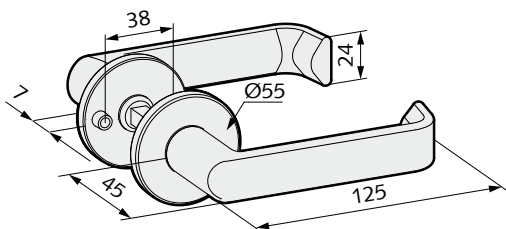

With handle roses

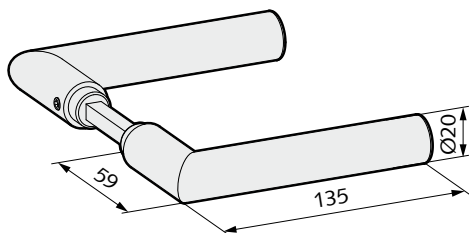

With shoulder guide

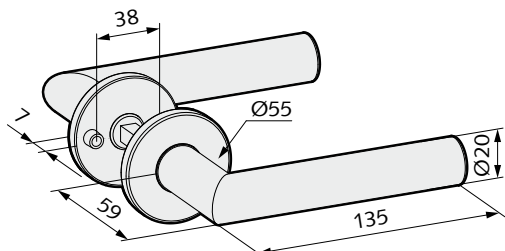

With handle roses

Handle, round shape¹

With shoulder guide

Part#	Corrosion protection
22.100.0000.---	Class 3

With handle roses

Part#	Corrosion protection
22.200.0000.---	Class 3

Available finishes:

- .112 Al E4/C-0 silver anodized
- .137 Al E4/C-31 stainless steel anodized
- .199 Al in special colour anodized
- .250 Al RAL 9010 pure white powder coated
- .295 Al RAL powder coated
- .416 Stainless Steel 304 polished
- .426 Stainless Steel 304 matt brushed

Handle, flat oval shape

With shoulder guide

Part#	Corrosion protection
22.104.0000.---	Class 3

With handle roses

Part#	Corrosion protection
22.204.0000.---	Class 3

Available finishes:

- .112 Al E4/C-0 silver anodized
- .137 Al E4/C-31 stainless steel anodized
- .199 Al in special colour anodized
- .250 Al RAL 9010 pure white powder coated
- .295 Al RAL powder coated

Handle, mitred shape¹

With shoulder guide

Part#	Corrosion protection
22.108.0000.---	Class 3

With handle roses

Part#	Corrosion protection
22.208.0000.---	Class 3

Available finishes:

- .112 Al E4/C-0 silver anodized
- .137 Al E4/C-31 stainless steel anodized
- .199 Al in special colour anodized
- .250 Al RAL 9010 pure white powder coated
- .295 Al RAL powder coated
- .416 Stainless Steel 304 polished
- .426 Stainless Steel 304 matt brushed

¹ The handles in Stainless Steel 304 matt brushed (---.426) and Stainless Steel 304 polished (---.416) can be combined with the locks in Al stainless steel finish (---.198) and Al polished chrome (---.174).

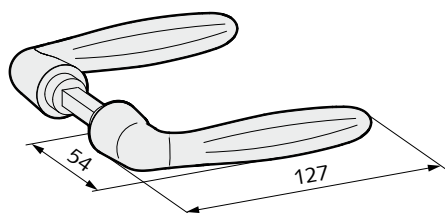

With shoulder guide

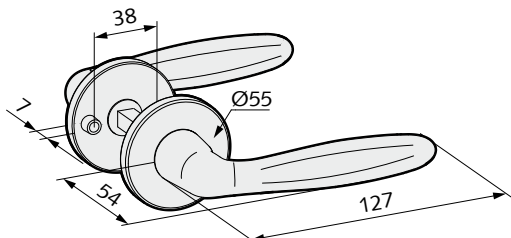

With handle roses

Handle, convex shape

With shoulder guide

Part#	Corrosion protection
22.112.0000.---	Class 3

With handle roses

Part#	Corrosion protection
22.212.0000.---	Class 3

Available finishes:

- .112 Al E4/C-0 silver anodized
- .137 Al E4/C-31 stainless steel anodized
- .199 Al in special colour anodized
- .250 Al RAL 9010 pure white powder coated
- .295 Al RAL powder coated

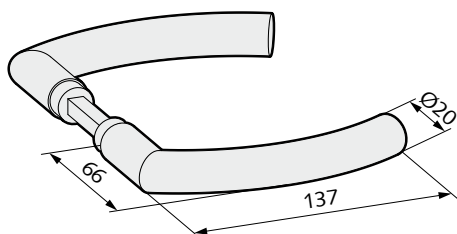

With shoulder guide

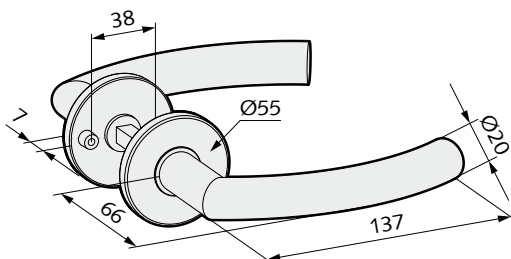

With handle roses

Handle, bent shape²

With shoulder guide

Part#	Corrosion protection	Material/finish
22.130.0000.426	Class 3	304 matt brushed

With handle roses

Part#	Corrosion protection	Material/finish
22.230.0000.426	Class 3	304 matt brushed

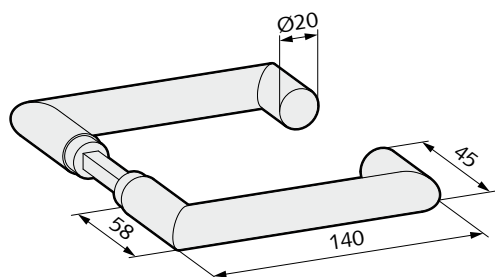

With shoulder guide

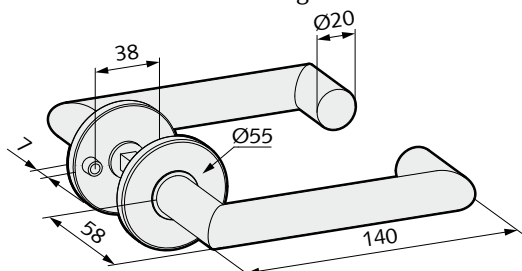

With handle roses

Handle, square shape²

With shoulder guide

Part#	Corrosion protection	Material/finish
22.134.0000.426	Class 3	304 matt brushed

With handle roses

Part#	Corrosion protection	Material/finish
22.234.0000.426	Class 3	304 matt brushed

² The handles in Stainless Steel 304 matt brushed (---.426) can be combined with the locks in Al stainless steel finish (---.198).

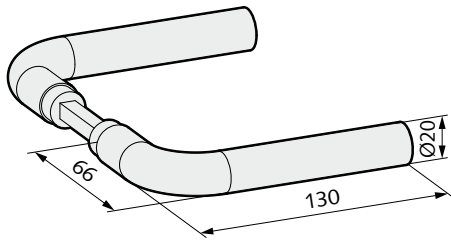

With shoulder guide

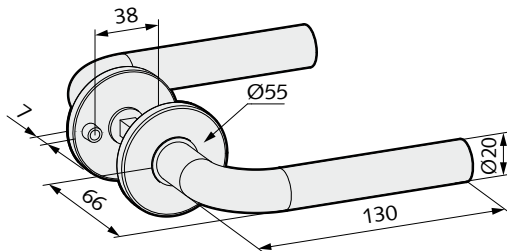

With handle roses

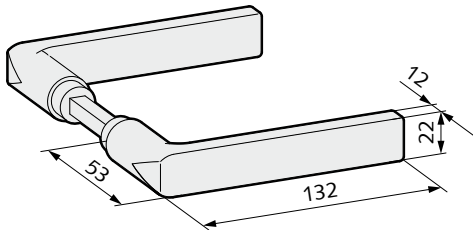

With shoulder guide

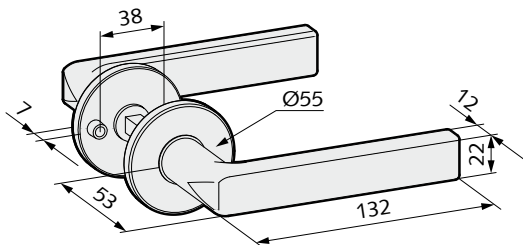

With handle roses

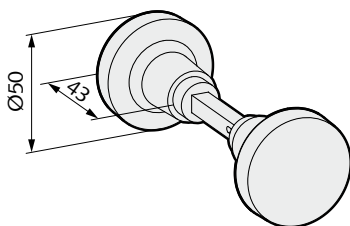

With shoulder guide

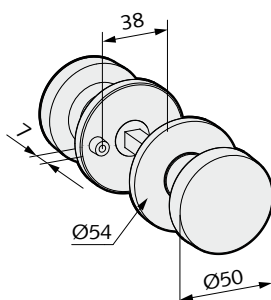

With handle roses

Handle, rod shape²

With shoulder guide

Part#	Corrosion protection	Material/finish
22.138.0000.426	Class 3	304 matt brushed

With handle roses

Part#	Corrosion protection	Material/finish
22.238.0000.426	Class 3	304 matt brushed

Handle, angular shape²

With shoulder guide

Part#	Corrosion protection	Material/finish
22.142.0000.426	Class 3	304 matt brushed

With handle roses

Part#	Corrosion protection	Material/finish
22.242.0000.426	Class 3	304 matt brushed

Turning knob

With shoulder guide

Part#	Corrosion protection
22.150.0000.---	Class 3

With handle roses

Part#	Corrosion protection
22.250.0000.---	Class 3

Available finishes:

- .112 Al E4/C-0 silver anodized
- .137 Al E4/C-31 stainless steel anodized
- .199 Al in special colour anodized
- .250 Al RAL 9010 pure white powder coated
- .295 Al RAL powder coated

² The handles in Stainless Steel 304 matt brushed (---.426) can be combined with the locks in Al stainless steel finish (---.198).

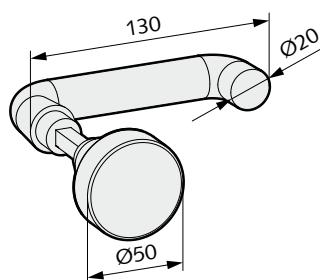

With shoulder guide

Handle, round shape and knob with no function

With shoulder guide

Part#	Corrosion protection
22.154.0000.---	Class 3

Available finishes:

- .112 Al E4/C-0 silver anodized
- .137 Al E4/C-31 stainless steel anodized
- .199 Al in special colour anodized
- .250 Al RAL 9010 pure white powder coated
- .295 Al RAL powder coated
- .426 Stainless Steel 304 matt brushed

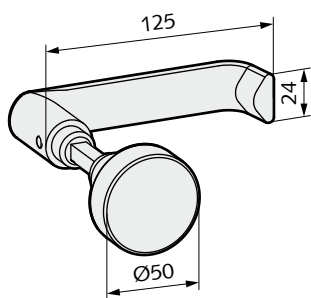

With shoulder guide

Handle, flat oval shape and knob with no function

With shoulder guide

Part#	Corrosion protection
22.156.0000.---	Class 3

Available finishes:

- .112 Al E4/C-0 silver anodized
- .137 Al E4/C-31 stainless steel anodized
- .199 Al in special colour anodized
- .250 Al RAL 9010 pure white powder coated
- .295 Al RAL powder coated

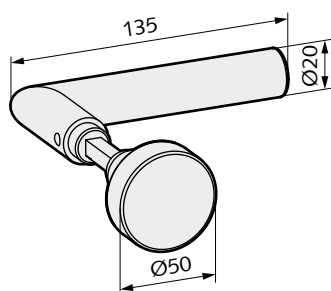

With shoulder guide

Handle, mitred shape and knob with no function

With shoulder guide

Part#	Corrosion protection
22.158.0000.---	Class 3

Available finishes:

- .112 Al E4/C-0 silver anodized
- .137 Al E4/C-31 stainless steel anodized
- .199 Al in special colour anodized
- .250 Al RAL 9010 pure white powder coated
- .295 Al RAL powder coated
- .426 Stainless Steel 304 matt brushed

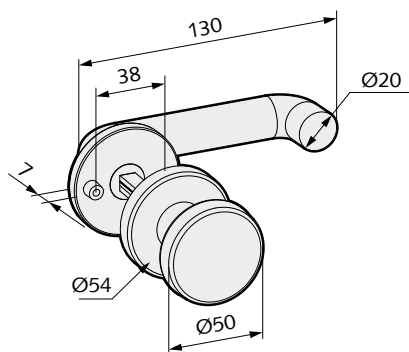

With handle roses

Handle, round shape and fixed knob

With handle roses

Part#	Corrosion protection
22.254.0000.---	Class 3

Available finishes:

- .112 Al E4/C-0 silver anodized
- .137 Al E4/C-31 stainless steel anodized
- .199 Al in special colour anodized
- .250 Al RAL 9010 pure white powder coated
- .295 Al RAL powder coated
- .426 Stainless Steel 304 matt brushed

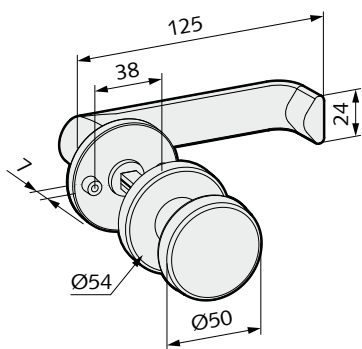

With handle roses

Handle, flat oval shape and fixed knob

With handle roses

Part#	Corrosion protection
22.256.0000.---	Class 3

Available finishes:

- .112 Al E4/C-0 silver anodized
- .137 Al E4/C-31 stainless steel anodized
- .199 Al in special colour anodized
- .250 Al RAL 9010 pure white powder coated
- .295 Al RAL powder coated

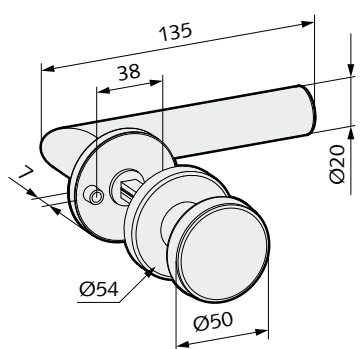

With handle roses

Handle, mitred shape and fixed knob

With handle roses

Part#	Corrosion protection
22.258.0000.---	Class 3

Available finishes:

- .112 Al E4/C-0 silver anodized
- .137 Al E4/C-31 stainless steel anodized
- .199 Al in special colour anodized
- .250 Al RAL 9010 pure white powder coated
- .295 Al RAL powder coated
- .426 Stainless Steel 304 matt brushed

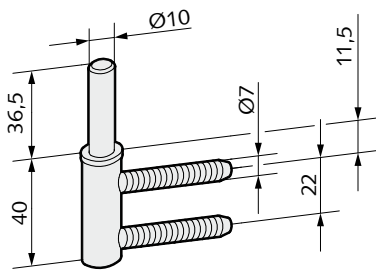

Frame part for wooden frames

- For fixing plate V 3614

Part#	Corrosion protection	Material/finish
20.902.0000.010	Class 0	St galvanized

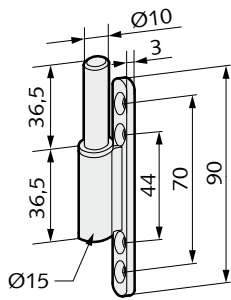

Frame part for wooden, steel and aluminium frames

- For screwing on

Part#	Corrosion protection	Material/finish
20.904.0000.010	Class 0	St galvanized

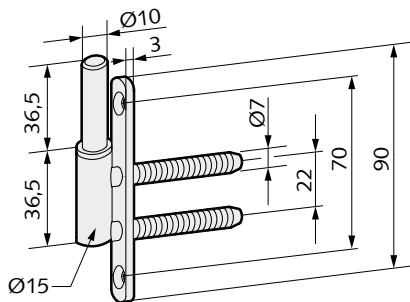

Frame part for wooden frames

- For screwing on, for fixing plate V 3614

Part#	Corrosion protection	Material/finish
20.906.0000.010	Class 0	St galvanized

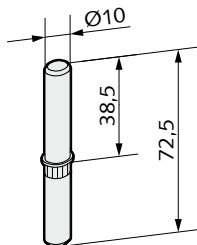

Bolts

- To convert frame parts

Part#	Corrosion protection	Material/finish
20.912.0000.010	Class 0	St galvanized

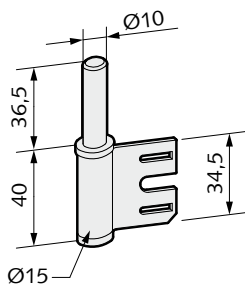

Frame part for steel frames

- For frame pocket V 8600

Part#	Corrosion protection	Material/finish
20.922.0000.010	Class 0	St galvanized

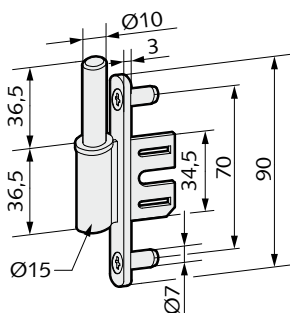

Frame part for steel frames

- For screwing on, for frame pocket V 8600

Part#	Corrosion protection	Material/finish
20.924.0000.010	Class 0	St galvanized

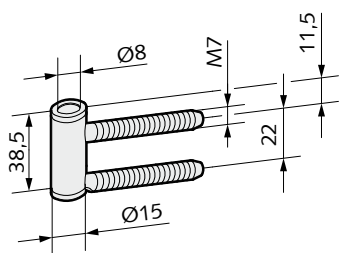

Frame part for wooden frames

- For fixing plate V 3614

Part#	Corrosion protection	Material/finish
21.400.0000.010	Class 0	St galvanized

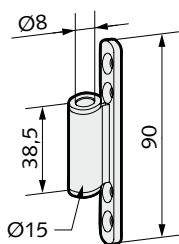

Frame part for wooden, steel and aluminium frames

- For screwing on

Part#	Corrosion protection	Material/finish
21.402.0000.010	Class 0	St galvanized

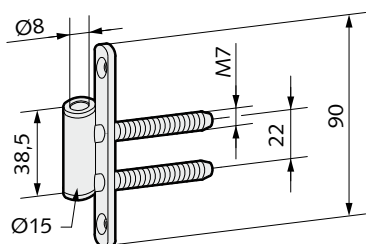

Frame part for wooden frames

- For screwing on, for fixing plate V 3614

Part#	Corrosion protection	Material/finish
21.404.0000.010	Class 0	St galvanized

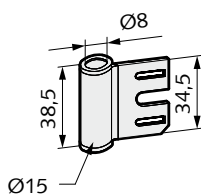

Frame part for steel frames

- For frame pocket V 8600

Part#	Corrosion protection	Material/finish
21.420.0000.010	Class 0	St galvanized

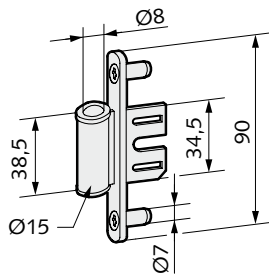

Frame part for steel frames

- For screwing on, for frame pocket V 8600

Part#	Corrosion protection	Material/finish
21.422.0000.010	Class 0	St galvanized

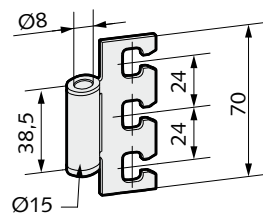

Frame part for steel frames

- For frame pocket VN 7608/120 3D

Part#	Corrosion protection	Material/finish
21.424.0000.010	Class 0	St galvanized

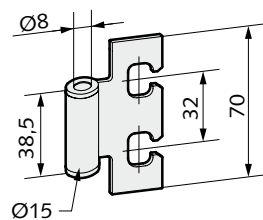

Frame part for steel frames

- For frame pocket VN 7608/160 3D

Part#	Corrosion protection	Material/finish
21.426.0000.010	Class 0	St galvanized

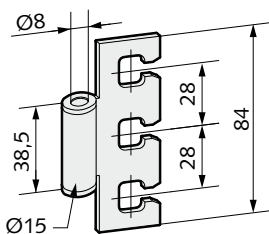

Frame part for wooden, steel and aluminium frames

- For frame pocket VX

Part#	Corrosion protection	Material/finish
21.440.0000.010	Class 0	St galvanized

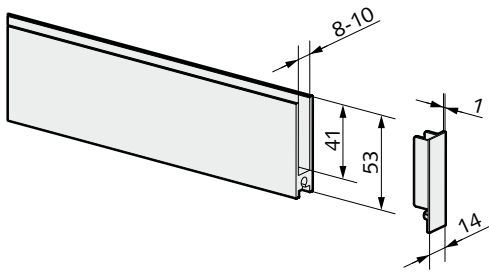

Door rail

- 53 mm profile height
- With plastic end caps on both sides
- With PVC gasket
- 30 mm glass inset

Part#	Glass thickness	Leaf width	Corrosion protection
26.102.0400.---	8 mm	834 mm	Class 4
26.104.0400.---	8 mm	959 mm	Class 4
26.106.0400.---	8 mm	to size	Class 4

Available finishes:

- .112 Al E4/C-0 silver anodized
- .137 Al E4/C-31 stainless steel anodized
- .199 Al in special colour anodized
- .250 Al RAL 9010 pure white powder coated
- .295 Al RAL powder coated

Note:

The door rail can also be used without a PVC gasket and with shorter plastic end caps for 10 mm glass. The door rail must also be stuck to the glass door with silicone. When ordering to size, please specify the exact leaf width (max. 1.200 mm).

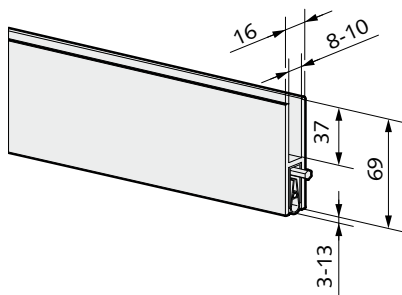

Door rail with automatic drop-down seal

- 69 mm profile height
- With PVC gasket
- 30 mm glass inset

Part#	Glass thickness	Leaf width	Corrosion protection
26.132.0400.---	8 mm	834 mm	Class 0
26.134.0400.---	8 mm	959 mm	Class 0
26.136.0400.---	8 mm	to size	Class 0

Available finishes:

- .112 Al E4/C-0 silver anodized
- .137 Al E4/C-31 stainless steel anodized
- .199 Al in special colour anodized
- .250 Al RAL 9010 pure white powder coated
- .295 Al RAL powder coated

Note:

The door rail can also be used without a PVC gasket for 10 mm glass. The door rail must also be stuck to the glass door with silicone. When ordering to size, please specify the exact leaf width (max. 1.200 mm).

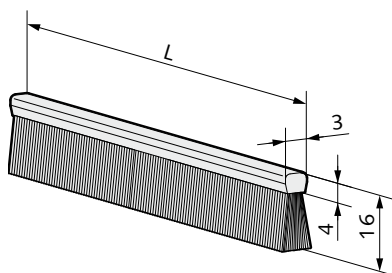

Brush seal

- For door rails with a 53 mm profile height
- Plastic natural

Part#	Leaf width	Corrosion protection
26.162.0000.505	834 mm	Class 0
26.164.0000.505	959 mm	Class 0
26.166.0000.505	to size	Class 0

Note:

When ordering to size, please specify the exact leaf width (max. 1.200 mm).

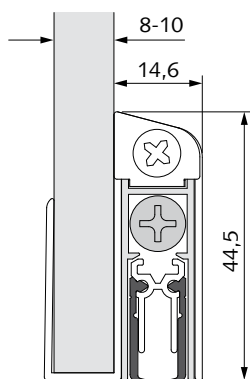

"SCHALL-EX®" door seal GS-8/GS-10

- With automatic drop-down seal
- One-sided triggering
- Max. 11 mm lift
- Door seal can be shortened by max. 125 mm

Part#	Glass thickness	Leaf width	Corrosion protection
26.170.0400.---	8 mm	834 mm	Class 0
26.172.0400.---	8 mm	959 mm	Class 0
26.174.0400.---	8 mm	1.084 mm	Class 0
26.176.0900.---	10 mm	834 mm	Class 0
26.178.0900.---	10 mm	959 mm	Class 0
26.180.0900.---	10 mm	1.084 mm	Class 0

Available finishes:

- .114 Al E6/C-0 silver anodized
- .139 Al E6/C-31 stainless steel anodized

Note:

The door seal must also be stuck to the glass door with silicone.

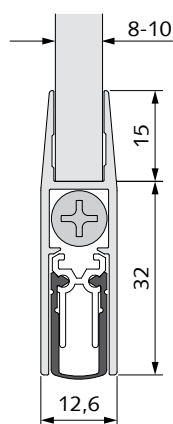

"SCHALL-EX®" door seal GS-H8/GS-H10

- With automatic drop-down seal
- One-sided triggering
- Max. 11 mm lift
- Door seal can be shortened by max. 125 mm
- 15 mm glass inset

Part#	Glass thickness	Leaf width	Corrosion protection
26.182.0400.---	8 mm	834 mm	Class 0
26.184.0400.---	8 mm	959 mm	Class 0
26.186.0400.---	8 mm	1.084 mm	Class 0
26.188.0900.---	10 mm	834 mm	Class 0
26.190.0900.---	10 mm	959 mm	Class 0
26.192.0900.---	10 mm	1.084 mm	Class 0

Available finishes:

- .114 Al E6/C-0 silver anodized
- .139 Al E6/C-31 stainless steel anodized

Note:

The door seal must also be stuck to the glass door with silicone.

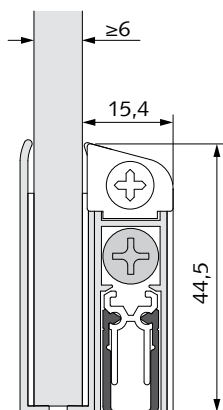

"SCHALL-EX®" door seal GS-A

- With automatic drop-down seal
- One-sided triggering
- Self-adhesive
- Max. 11 mm lift
- Door seal can be shortened by max. 125 mm

Part#	Glass thickness	Leaf width	Corrosion protection
26.194.0000.---	≥ 6 mm	834 mm	Class 0
26.196.0000.---	≥ 6 mm	959 mm	Class 0
26.198.0000.---	≥ 6 mm	1.084 mm	Class 0

Available finishes:

- .114 Al E6/C-0 silver anodized
- .139 Al E6/C-31 stainless steel anodized

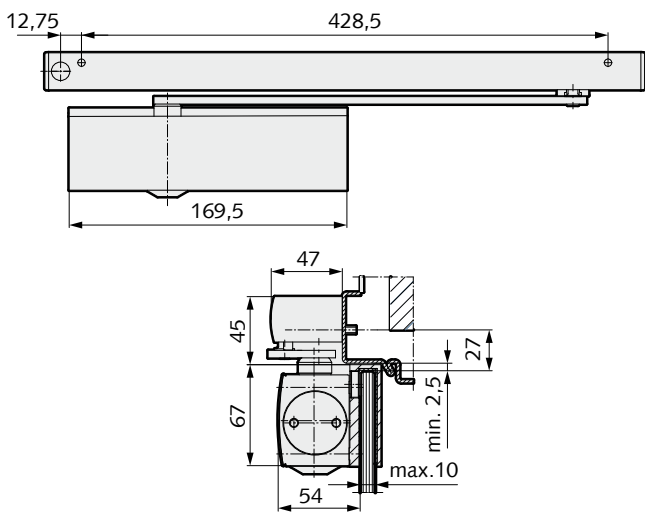

GEZE TS 3000 V door closer with glass clamp shoe

- Overhead door closer with guide rail
- For single action doors
- Max. leaf width: 1.100mm
- Infinitely variable closing force according to EN 1154 (size 1-4)
- St silver lacquered

Part#	Glass thickness	Corrosion protection
26.700.0500.035	8-10 mm	Class 4

Note:
We recommend the use of 3 hinges when using a door closer. Please pay attention to the details page 61-62.

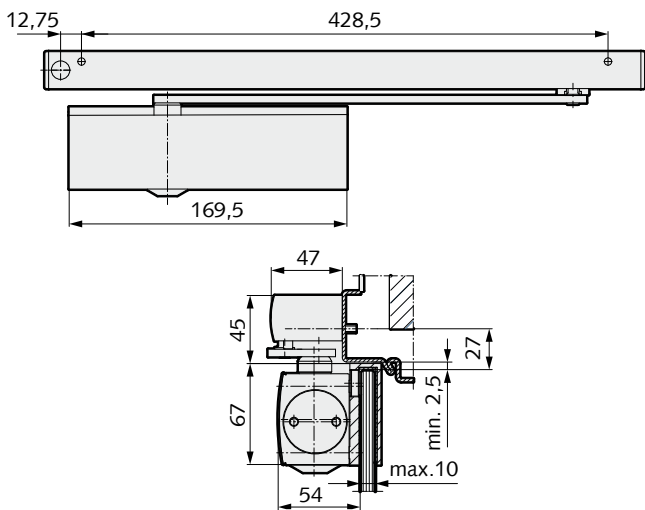

GEZE TS 3000 RF door closer with glass clamp shoe

- Overhead door closer with guide rail
- With mechanical locking unit**
- Locked position: 80° to 130°** (infinitely variable)
- For single action doors
- Max. leaf width: 1.100mm
- Infinitely variable closing force according to EN 1154 (size 1-4)
- St silver lacquered

Part#	Glass thickness	Corrosion protection
26.702.0500.035	8-10 mm	Class 4

Note:
We recommend the use of 3 hinges when using a door closer. Please pay attention to the details page 61-62.

Explanation of the closing force/size adjustment

The closing force is controlled by the initial tension of the door closer's spring force. This can be set infinitely with an adjusting screw. The closing force must be chosen to suit the door width. Details can be found in the table.

Closing force/size	Door width
1	up to 750 mm
2	> 750 to 850 mm
3	> 850 to 950 mm
4	> 950 to 1.100 mm

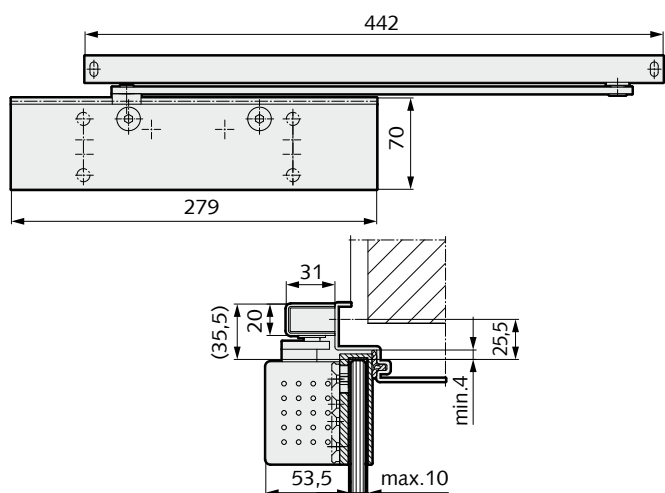

DORMA TS 92 door closer with glass door shoe

- Overhead door closer with guide rail
- For single action doors
- Max. leaf width: 1.100mm
- Infinitely variable closing force according to EN 1154 (size 1-4)
- St silver lacquered

Part#	Glass thickness	Corrosion protection
26.710.0500.035	8-10 mm	Class 3

Note:
We recommend the use of 3 hinges when using a door closer. Please pay attention to the details page 61-62.

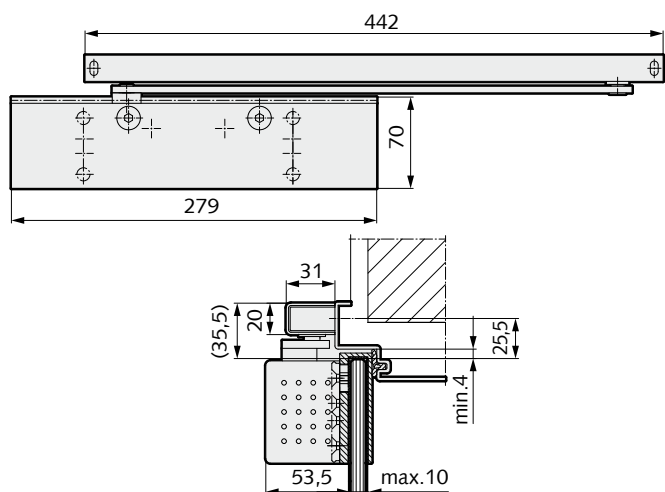

DORMA TS 92 door RF closer with glass door shoe

- Overhead door closer with guide rail
- With mechanical locking unit**
- Locked position: 80° to 130°** (infinitely variable)
- For single action doors
- Max. leaf width: 1.100mm
- Infinitely variable closing force according to EN 1154 (size 1-4)
- St silver lacquered

Part#	Glass thickness	Corrosion protection
26.712.0500.035	8-10 mm	Class 3

Note:
We recommend the use of 3 hinges when using a door closer. Please pay attention to the details page 61-62.

Explanation of the closing force/size adjustment

The closing force is controlled by the initial tension of the door closer's spring force. This can be set infinitely with an adjusting screw. The closing force must be chosen to suit the door width. Details can be found in the table.

Closing force/size	Door width
1	up to 750 mm
2	> 750 to 850 mm
3	> 850 to 950 mm
4	> 950 to 1.100 mm

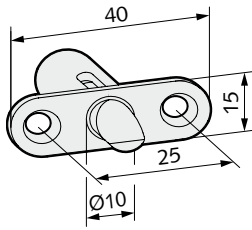

Door catch

Part#	Corrosion protection	Material/finish
26.200.0000.114	Class 3	Al E6/C-0 silver anod.

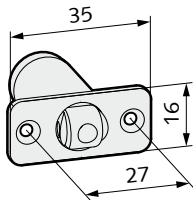

Door catch with roller latch

Part#	Corrosion protection	Material/finish
26.201.0000.550	Class 0	Plastic white

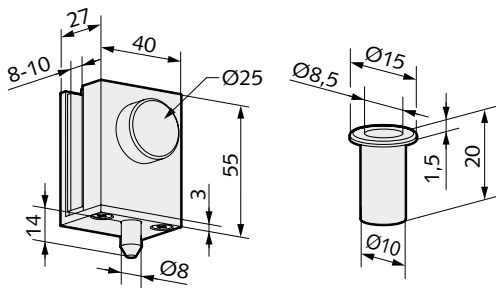

Slide-over door bolt

- With matt nickel-plated brass floor bush

Part#	Glass thickness	Corrosion protection
26.202.0400.---	8 mm	Class 2
26.202.0900.---	10 mm	Class 2

Available finishes:

- .112 Al E4/C-0 silver anodized
- .137 Al E4/C-31 stainless steel anodized
- .174 Al polished chrome
- .198 Al stainless steel finish
- .199 Al in special colour anodized
- .250 Al RAL 9010 pure white powder coated
- .295 Al RAL powder coated

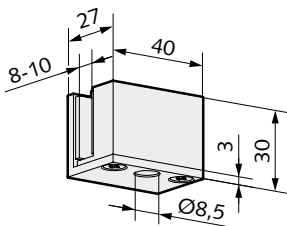

Slide-over striker box

- For slide-over door bolt

Part#	Glass thickness	Corrosion protection
26.204.0400.---	8 mm	Class 3
26.204.0900.---	10 mm	Class 3

Available finishes:

- .112 Al E4/C-0 silver anodized
- .137 Al E4/C-31 stainless steel anodized
- .174 Al polished chrome
- .198 Al stainless steel finish
- .199 Al in special colour anodized
- .250 Al RAL 9010 pure white powder coated
- .295 Al RAL powder coated

Note:

A minimum gap of 10 mm has to be guaranteed when using the slide-over door bolt in conjunction with the slide-over striker box.

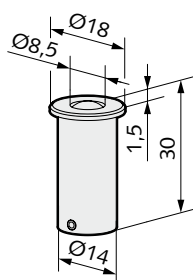

Floor bush with spring-loaded dust protector

- For round bolt Ø 8 mm

Part#	Corrosion protection	Material/finish
26.206.0000.010	Class 2	St galvanized

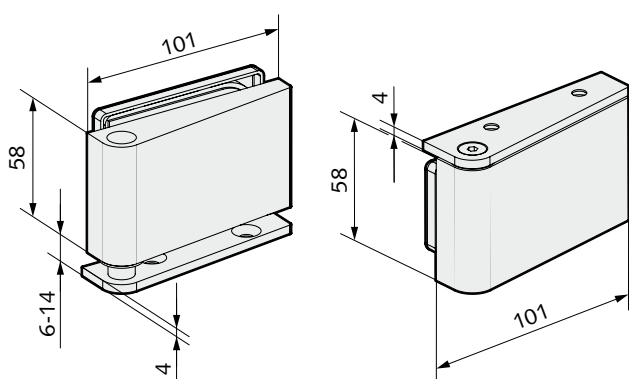

Corner hinges

- With screw-on top and bottom pivots
- Suitable for door weights up to 80 kg
- Max. door width 1.100 mm

Part#	Glass thickness	Corrosion protection
26.300.0600.---	8-12 mm	Class 2

Available finishes:

- .112 Al E4/C-0 silver anodized
- .137 Al E4/C-31 stainless steel anodized
- .174 Al polished chrome
- .198 Al stainless steel finish
- .199 Al in special colour anodized
- .250 Al RAL 9010 pure white powder coated
- .295 Al RAL powder coated

Note:

Please pay attention to glass processing on page 63.

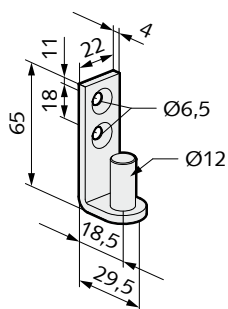

Wall bracket for corner hinges

- Suitable for door weights up to 40 kg

Part#	Corrosion protection	Material/finish
26.301.0000.426	Class 4	304 matt brushed

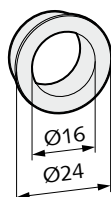

Handle guide

- To fit handles with a 16 mm shoulder guide

Part#	Corrosion protection	Material/finish
26.310.0000.565	Class 4	Plastic black

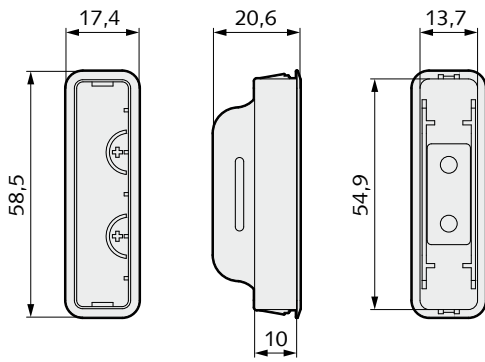

Magnetic insert

- For locks with magnetic latches
- For use with striking plates provided by the customer

Part#	Corrosion protection	Material/finish
26.320.0000.570	Class 4	Plastic grey

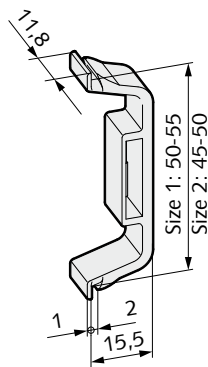

Magnetic clip

- For locks with magnetic latches

Part#	Size	Corrosion protection	Material/finish
26.330.0000.505	1	Class 4	Plastic natural
26.332.0000.505	2	Class 4	Plastic natural

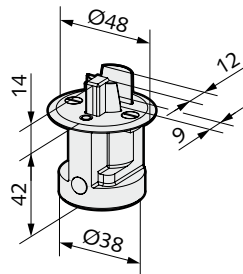

Floor-mounted retainer

- 304 matt brushed

Part#	Glass thickness	Corrosion protection
26.400.0500.426	8-10 mm	Class 2

Note:

Press the trigger button to lock the door. Push the locking pin down to release the door again.

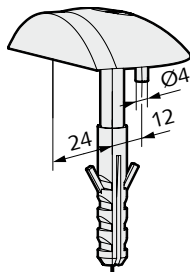

Door stop

- With black rubber buffer
- Suitable for door weights up to 50 kg

Part#	Corrosion protection
06.400.0000.---	Class 2

Available finishes:

- .112 Al E4/C-0 silver anodized
- .426 Stainless Steel 304 matt brushed

Note:

The door stop should be screwed to the floor as far from the hinge side as possible.

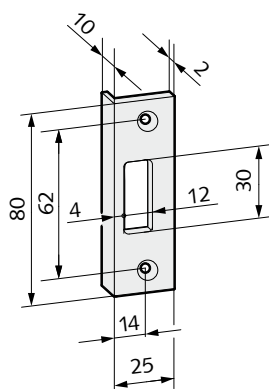

Striking plate

Part#	Corrosion protection	Material/finish
26.404.0000.426	Class 4	304 matt brushed

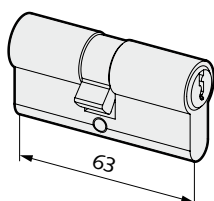

Profile cylinder

- According to DIN 18252 / EN 1303
- With 3 keys
- 63 mm long (31,5/31,5 mm)

Part#	Keying	Corrosion protection
01.901.3131.325	different keys	Class 3
01.903.3131.325	same keys	Class 3

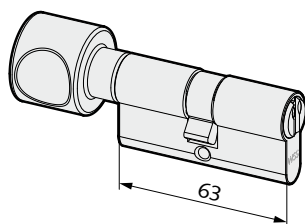

Profile thumb cylinder

- According to DIN 18252 / EN 1303
- With thumb turn (Al E6/C-0 silver anodized)
- With 3 keys
- 63 mm long (31.5/31.5 mm)
- Brass matt nickel plated

Part#	Keying	Corrosion protection
01.913.3131.325	different keys	Class 3
01.914.3131.325	same keys	Class 3



Colour swatch

- Aluminium:
 - E4/C-0 silver anodized ---.112
 - E4/C-31 stainless steel anodized ---.137
 - Polished chrome ---.174
 - Stainless steel finish ---.198
- Stainless steel:
 - Stainless Steel 304 polished ---.416
 - Stainless Steel 304 matt brushed ---.426

Part#
99.110.0000.999

Note:

The colour swatch is a non-binding sample. The surface appearance may differ from the original due to printing.

Glass processing

Glass door leaf prepared for STUDIO locks and STUDIO hinges when using standard frames according to DIN 18101

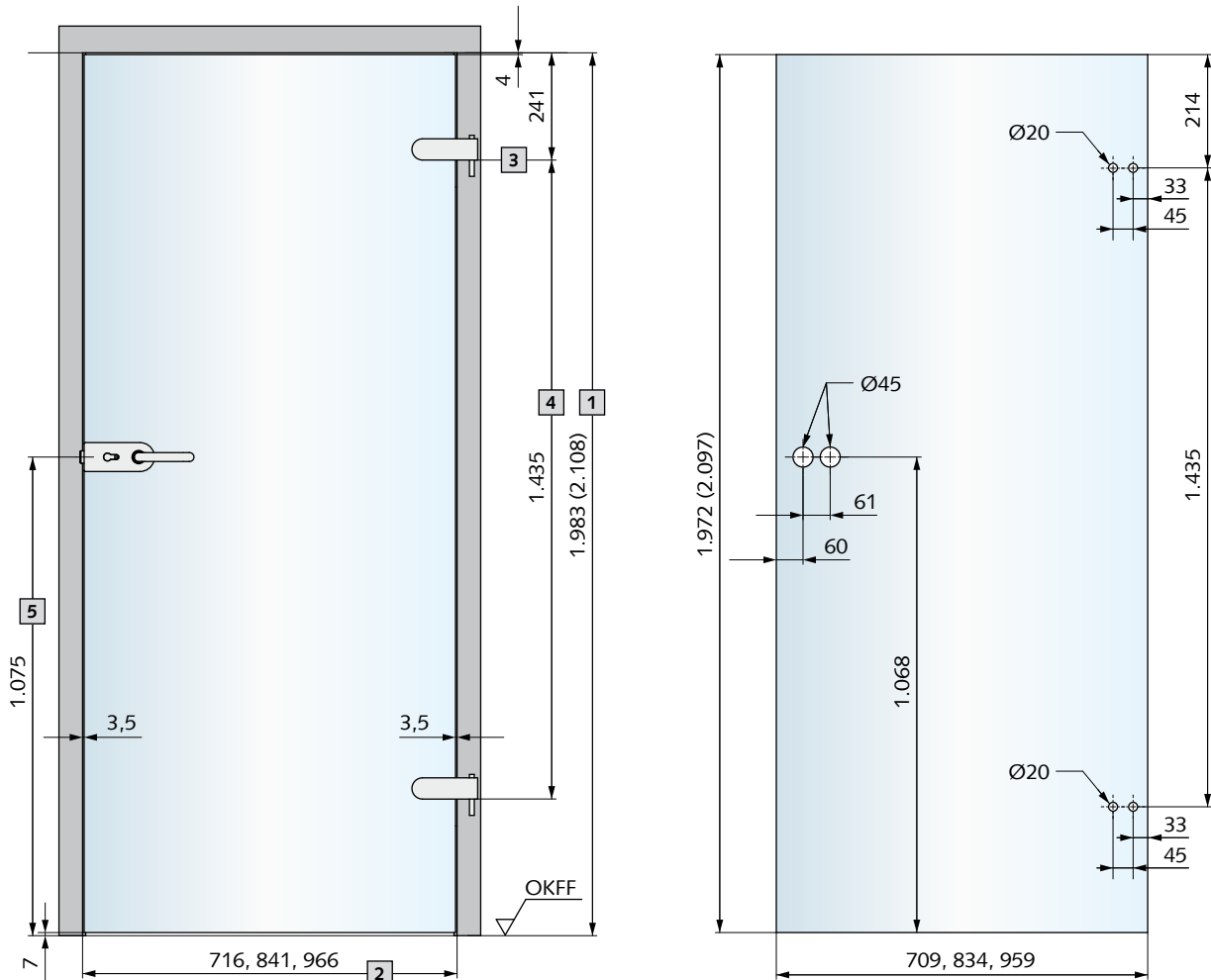

Explanations:

- 1 Door opening height
- 2 Door opening width
- 3 Hinge positions according to DIN 18268
- 4 Hinge positions according to DIN 18111
- 5 Surface of finished floor (OKFF) to centre of handle

Glass processing

Glass door leaf prepared for STUDIO locks and OBJEKT hinges when using standard frames according to DIN 18101

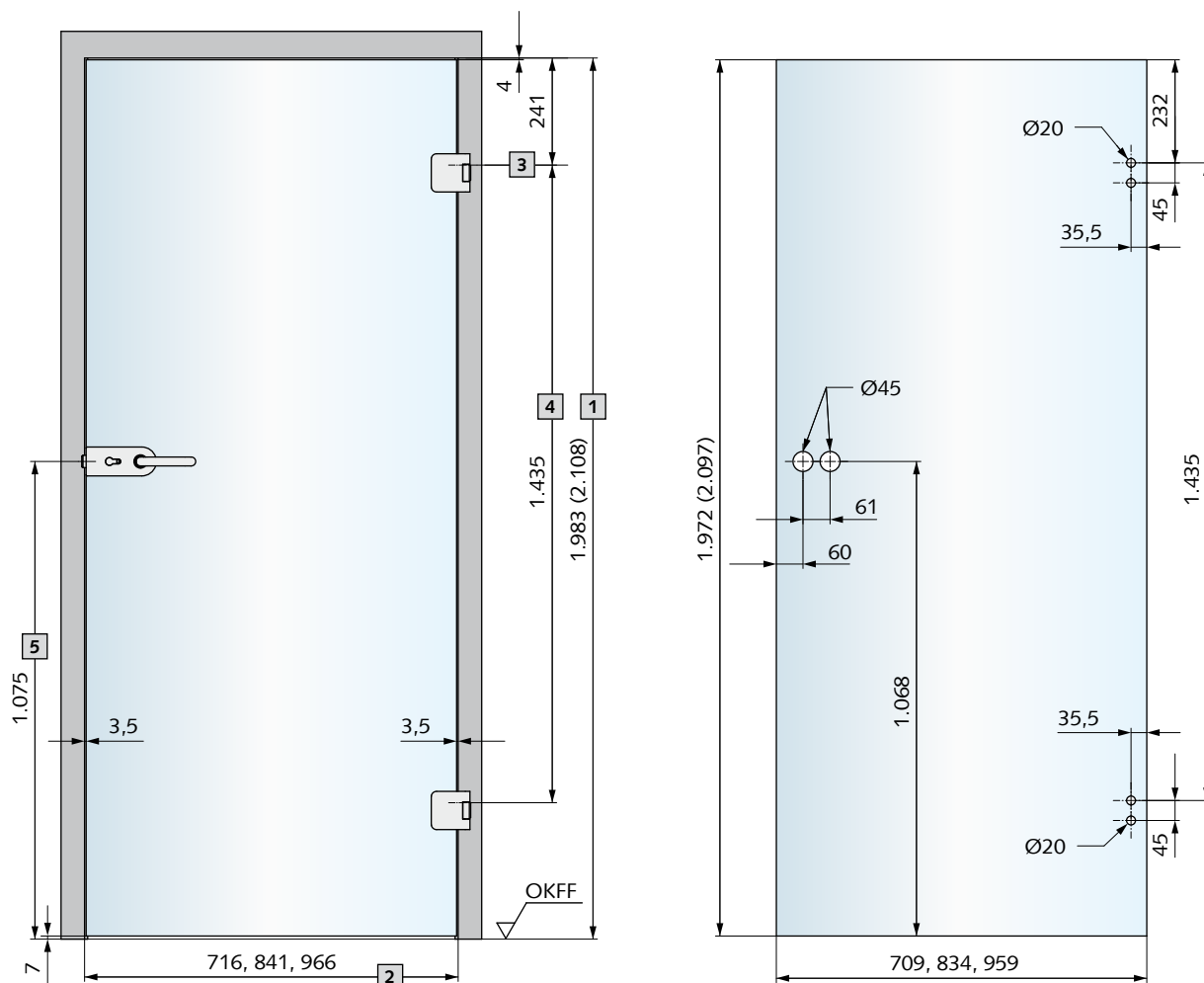

Explanations:

- 1 Door opening height
- 2 Door opening width
- 3 Hinge positions according to DIN 18268
- 4 Hinge positions according to DIN 18111
- 5 Surface of finished floor (OKFF) to centre of handle

Note:

If 3 hinges are used, we recommend positioning the top hinge in the upper third of the door (approx. 350 mm below the first reference line). Please agree on the position with the frame and door manufacturer.

Glass processing

Glass door leaf prepared for STUDIO locks and OBJEKT hinges with fixing plate for non-rebated door frames

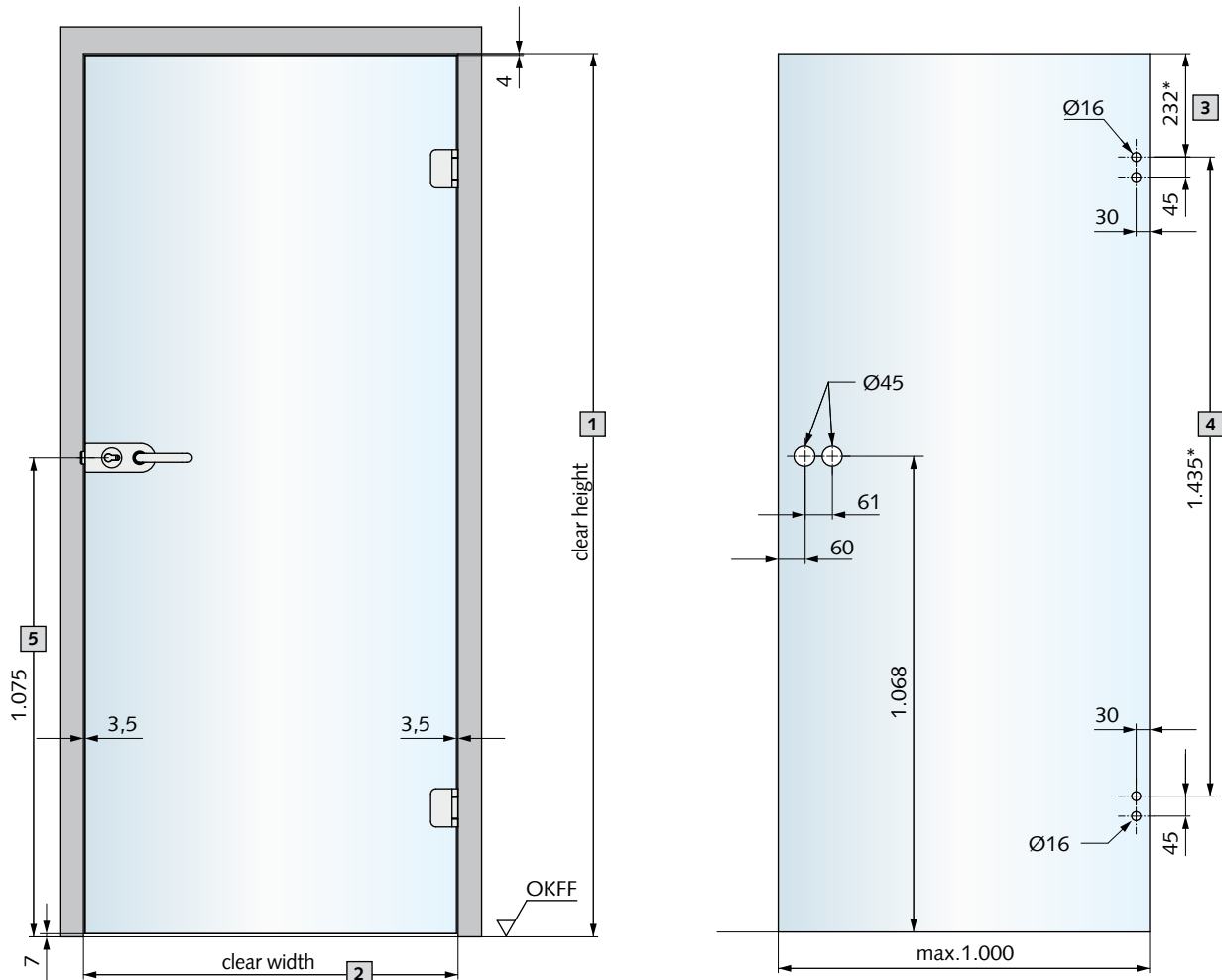

Explanations:

- 1 Door opening height
- 2 Door opening width
- 3 Hinge position according to DIN 18268
- 4 Hinge position according to DIN 18111
- 5 Surface of finished floor (OKFF) to centre of handle

Note:

If 3 hinges are used, we recommend positioning the top hinge in the upper third of the door (approx. 350mm below the first reference line). Please agree on the position with the frame and door manufacturer.

* Recommendation for leaf heights up to approx. 2.200mm (based on DIN 18101)

Glass processing

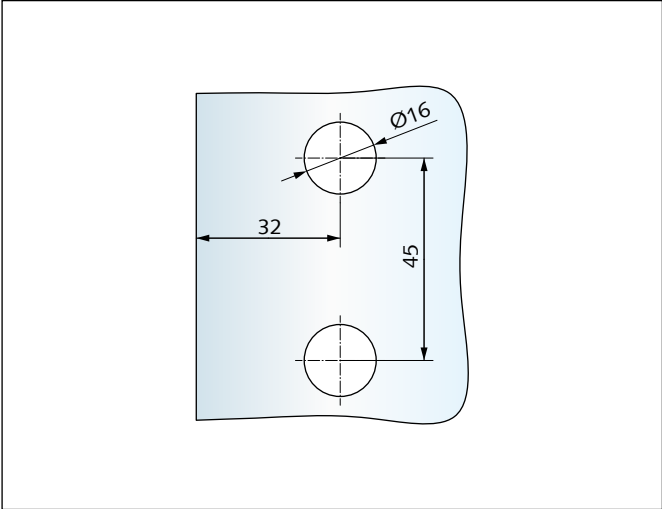

GK striker box, small (STUDIO OLIS / STUDIO ALEA)
Part# 20.257.0500.---

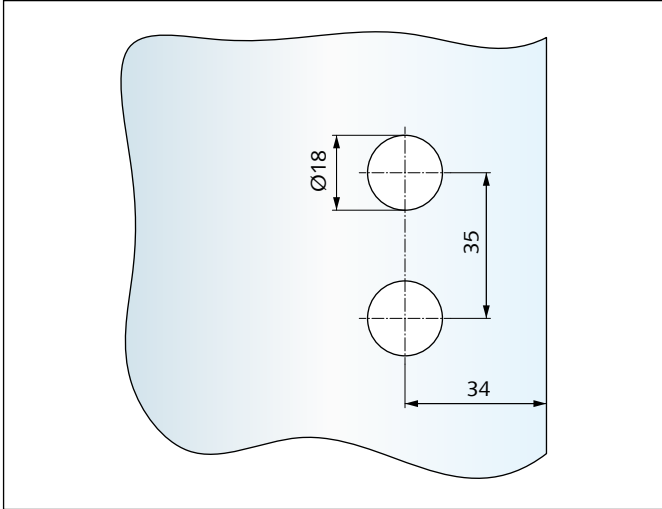

GK striker box, small (STUDIO VENA)
Part# 20.849.0500.---

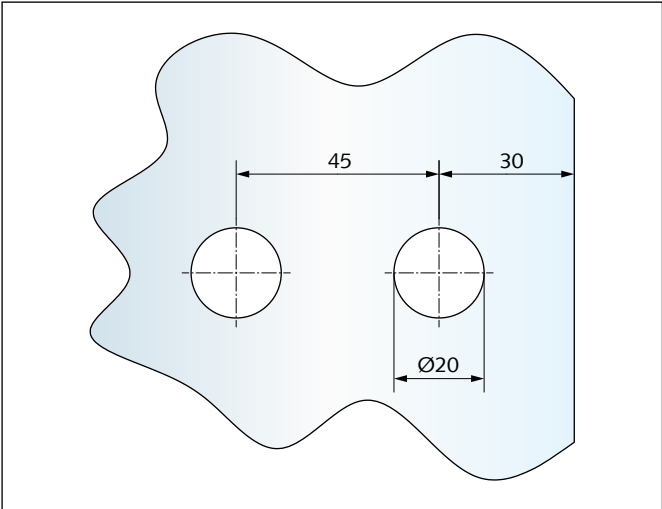

Screw-on hinge
Part# 20.312.0500.--- and 20.712.0500.---

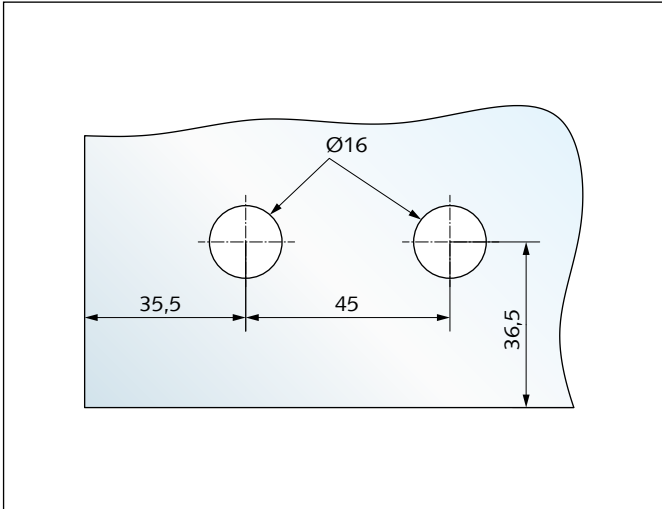

Corner hinge
Part# 26.300.0600.---

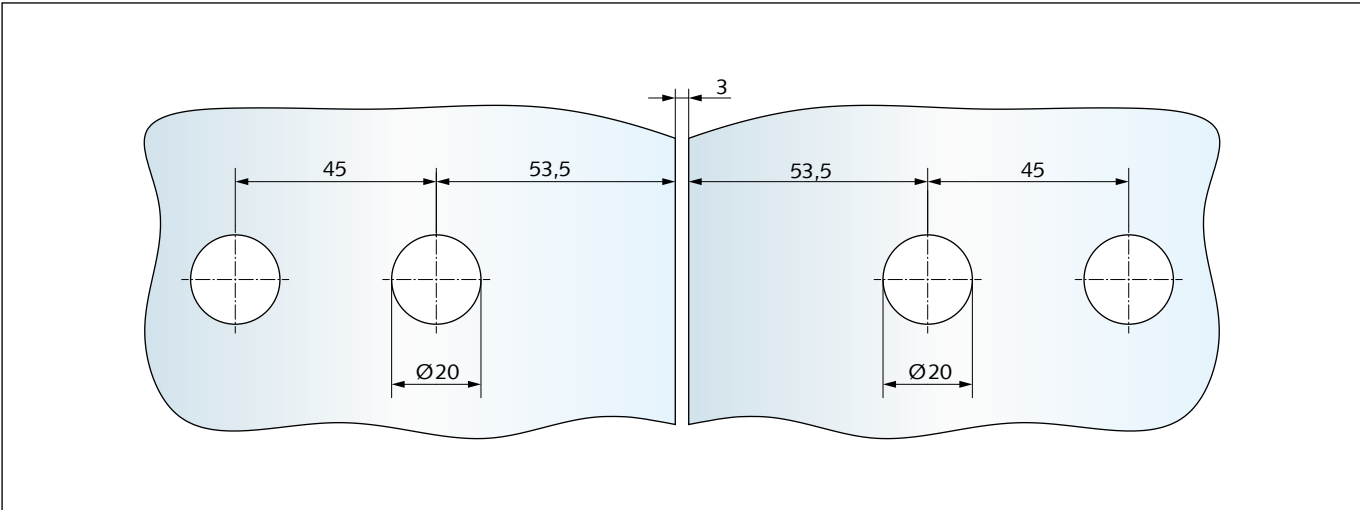

Hinge, glass-glass
Part# 20.318.0500.--- und 20.718.0500.---

Door weights

Choose the right combination!

Factors for the possible load

The load on a hinge is made up of not just the weight of the door but also various other factors. Pay attention to the following points, amongst others:

- Place of installation
- Opening frequency
- Door size
- Arrangement of the hinges
- Door stop
- Door closers
- Frame rebate depth
- Ball bearing

Residential homes: Series V

Hinges with frame parts in combination with the "Series V" frame pockets have proven to be suitable in residential homes with a normal frequency.





Commercial properties: Series VN and VX

In commercial and public properties with a higher frequency, hinges with frame parts in combination with frame pockets from the "Series VN" and "Series VX" have proven to be suitable. This sector includes public administrative and office buildings, doctor's surgeries, banks, restaurants etc.



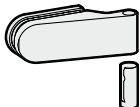
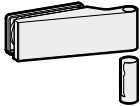
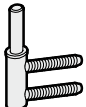

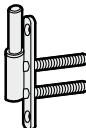

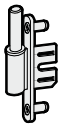

Please refer to the table for tested and practically proven door weights.

Hinges with ball bearings make the door run smoother but do not increase the weight of the door.

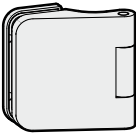
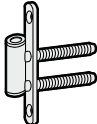
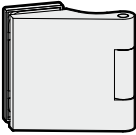
A permanent and perfect operation of the door can only be guaranteed with a vertical and professional installation.

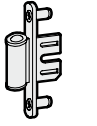
Hinge	Figure	Frame part Part#	Frame pocket Name	Max. door weight at frame rebate depth	
				24 mm	26-45 mm
Part# 20.300.0500.--- to 20.308.0902.---  or  Part# 20.700.0500.--- to 20.708.0902.---		20.902.0000.010	V 3614	45 kg	42 kg
		20.904.0000.010	–	45 kg	42 kg
		20.906.0000.010	V 3614	47 kg	47 kg
		20.922.0000.010	V 8600	45 kg	42 kg
		20.924.0000.010	V 8600	47 kg	47 kg



Hinge	Frame part		Frame pocket Name	Max. door weight at frame rebate depth	
	Figure	Part#		24 mm	26-45 mm
		21.400.0000.010	V 3614	45 kg	42 kg
Part# 21.300.0500.--- to 21.310.0520.---		21.402.0000.010	–	45 kg	42 kg
 or		21.404.0000.010	V 3614	47 kg	47 kg
		21.420.0000.010	V 8600	45 kg	42 kg
Part# 21.900.0500.--- to 21.910.0520.---		21.422.0000.010	V 8600	47 kg	47 kg
or		21.424.0000.010	VN 7608/120 3D	60 kg	48 kg
		21.426.0000.010	VN 7608/160 3D	60 kg	48 kg
Part# 20.880.0500.--- to 20.890.0520.---		21.440.0000.010	VX 7501 3D VX 7502 3D VX 7521 3D VX 7611 3D	60 kg	48 kg

Installation details

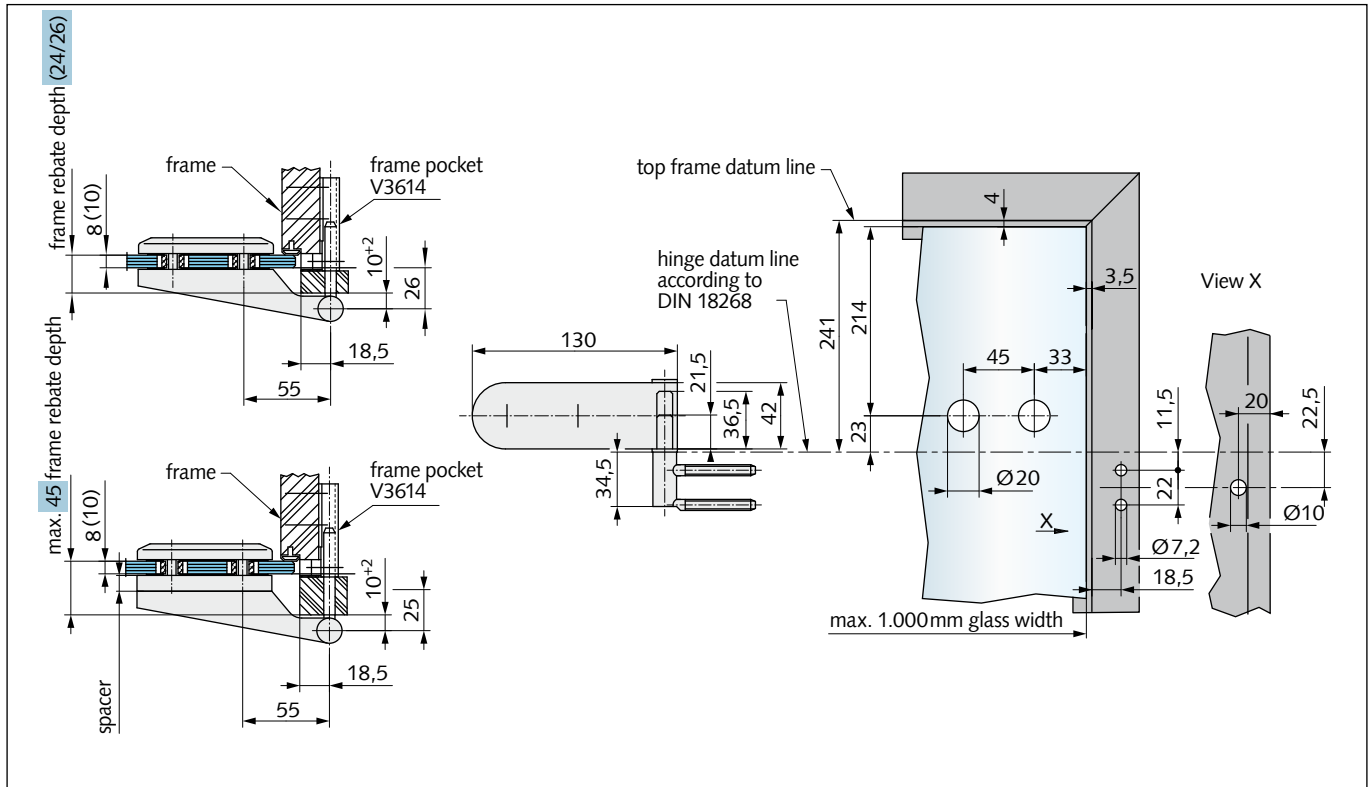

Hinge with frame part for wooden frames
 Part# 20.300.0500.--- to 20.308.0902.--- + 20.902.0000.010
 Part# 20.700.0500.--- to 20.708.0902.--- + 20.902.0000.010

Frame rebate depth	max. door weight
24 mm	45 kg
26–45 mm	42 kg

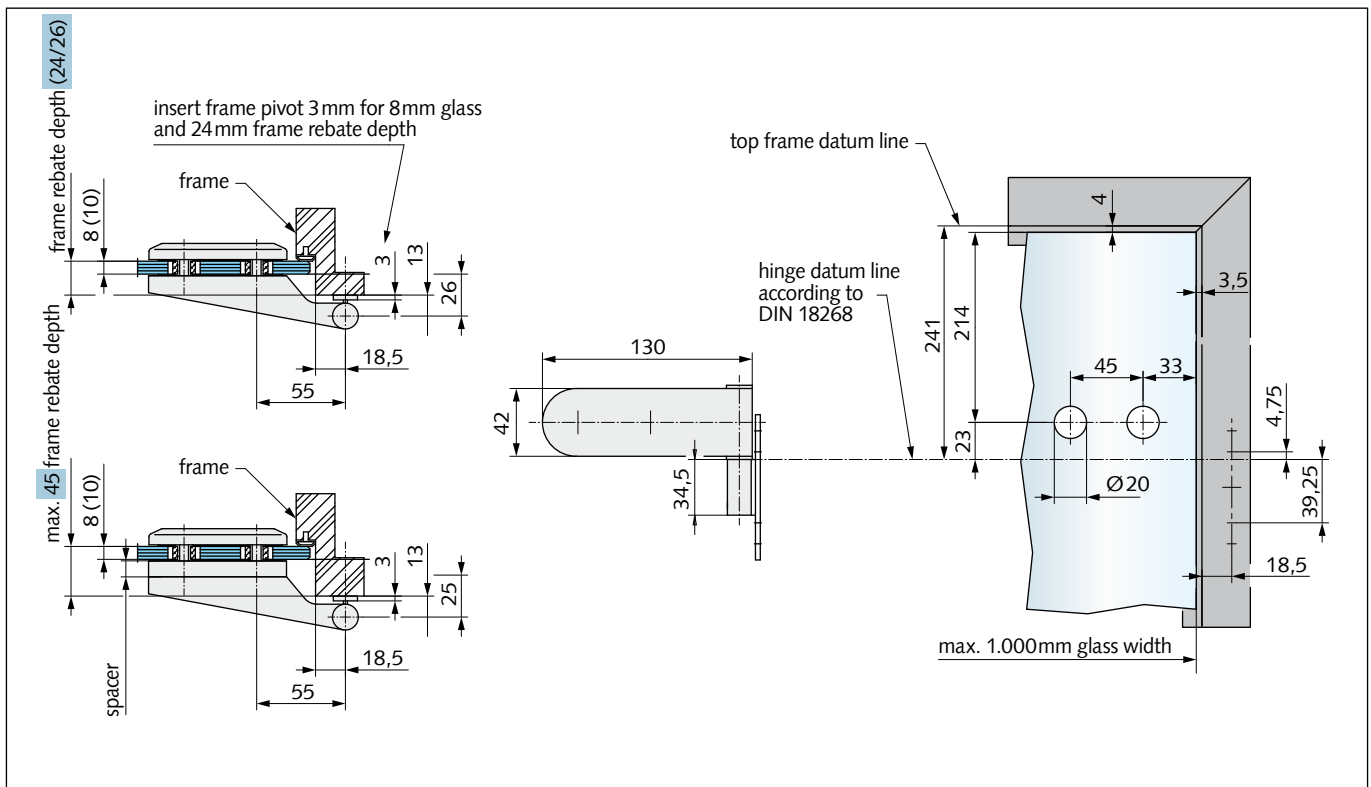

Hinge with frame part for wooden, steel and aluminium frames
 Part# 20.300.0500.--- to 20.308.0902.--- + 20.904.000.010
 Part# 20.700.0500.--- to 20.708.0902.--- + 20.904.000.010

Frame rebate depth	max. door weight
24 mm	45 kg
26–45 mm	42 kg

Installation details

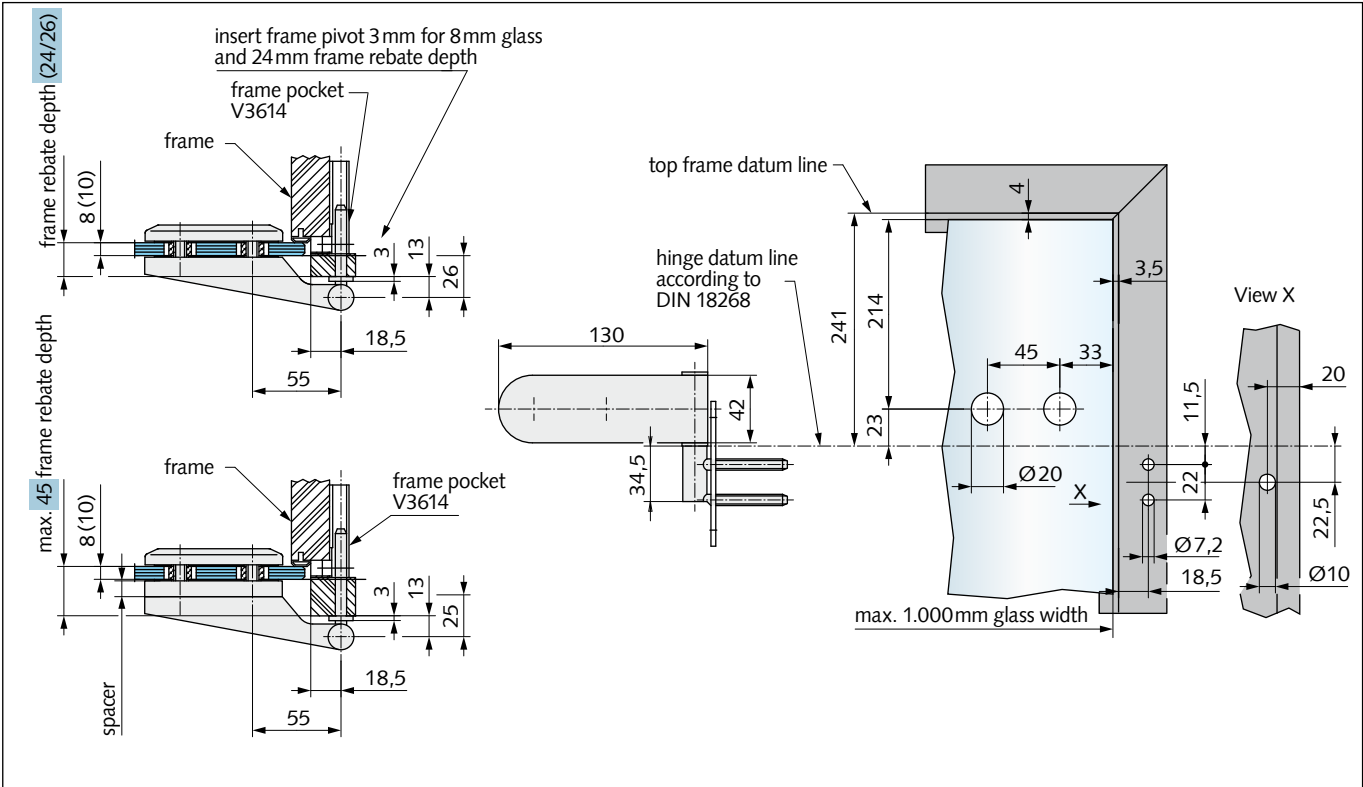

Hinge with frame part for wooden frames
 Part# 20.300.0500.--- to 20.308.0902.--- + 20.906.0000.010
 Part# 20.700.0500.--- to 20.708.0902.--- + 20.906.0000.010

Frame rebate depth	max. door weight
24 mm.....	47 kg
26–45 mm.....	47 kg

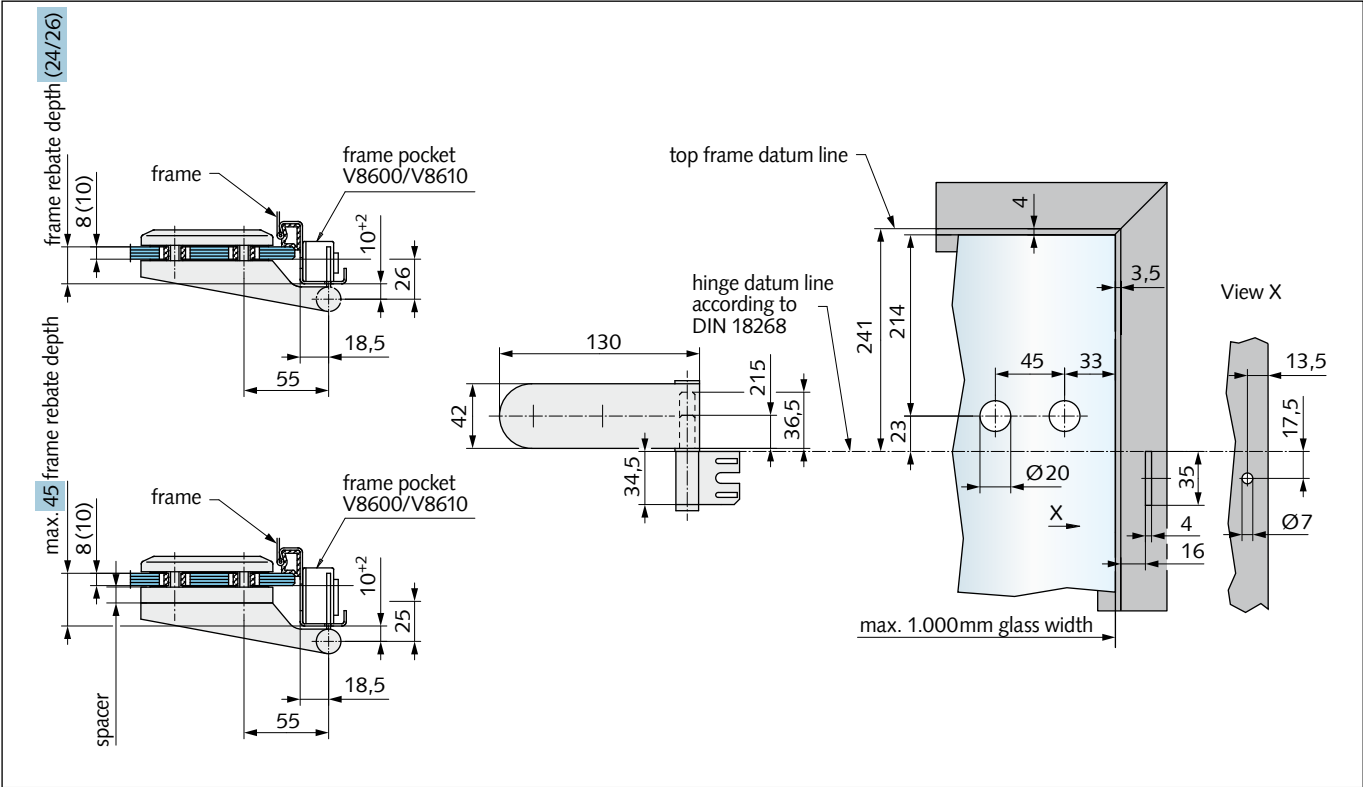

Hinge with frame part for steel frames
 Part# 20.300.0500.--- to 20.308.0902.--- + 20.922.0000.010
 Part# 20.700.0500.--- to 20.708.0902.--- + 20.922.0000.010

Frame rebate depth	max. door weight
24 mm.....	45 kg
26–45 mm.....	42 kg

Installation details

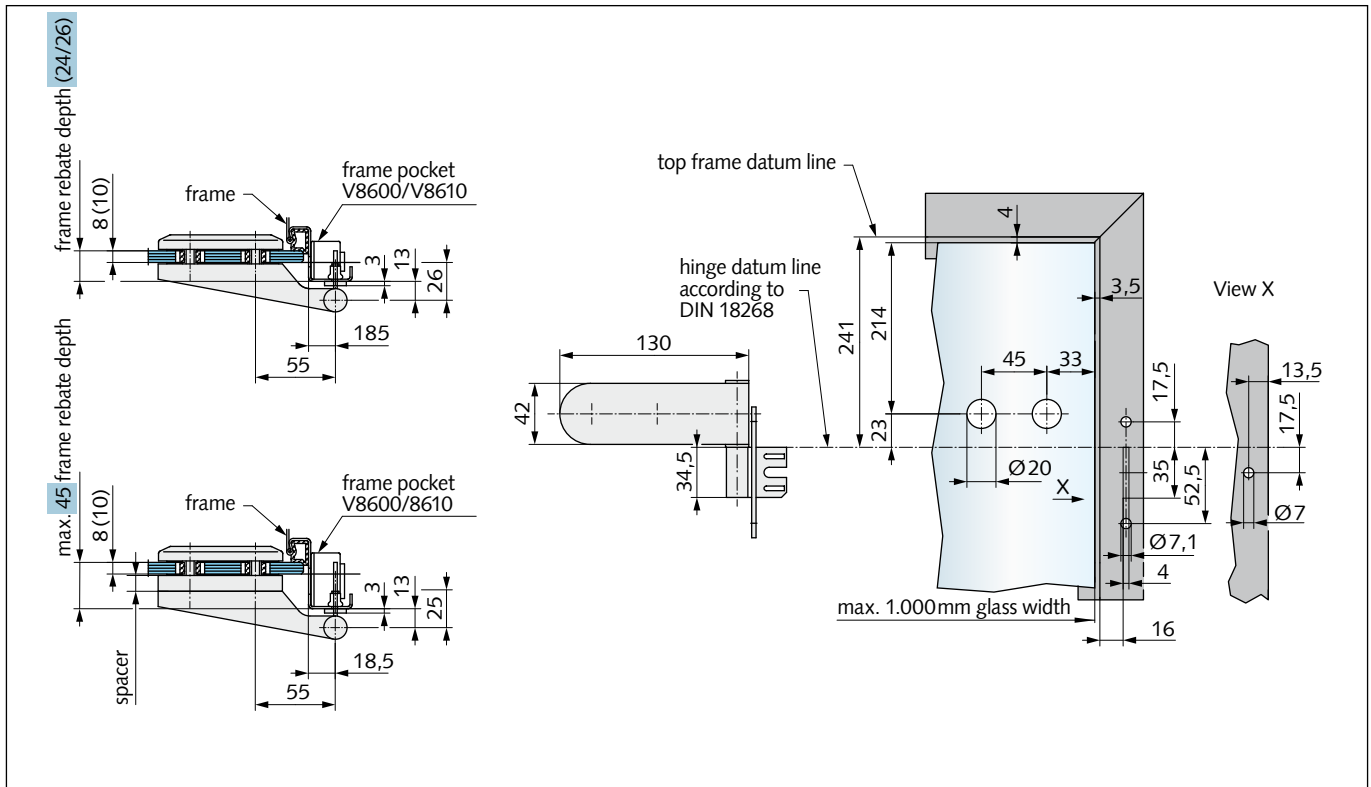

Hinge with frame part for steel frames
 Part# 20.300.0500.--- to 20.308.0902.--- + 20.924.0000.010
 Part# 20.700.0500.--- to 20.708.0902.--- + 20.924.0000.010

Frame rebate depth	max. door weight
24 mm	47 kg
26–45 mm	47 kg

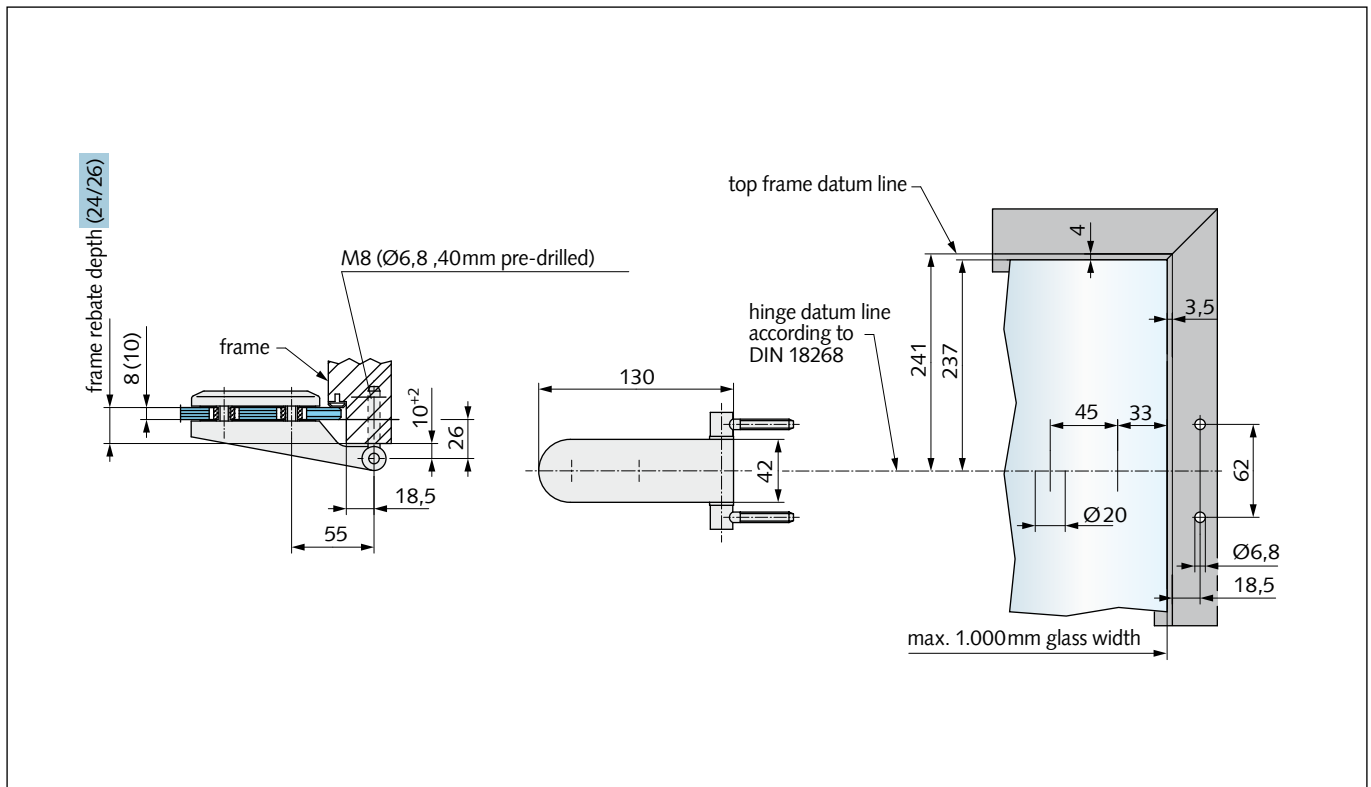

Hinge with frame parts for steel frames
 Part# 20.310.0500.---
 Part# 20.710.0500.---

Frame rebate depth	max. door weight
24 mm	35 kg

Installation details

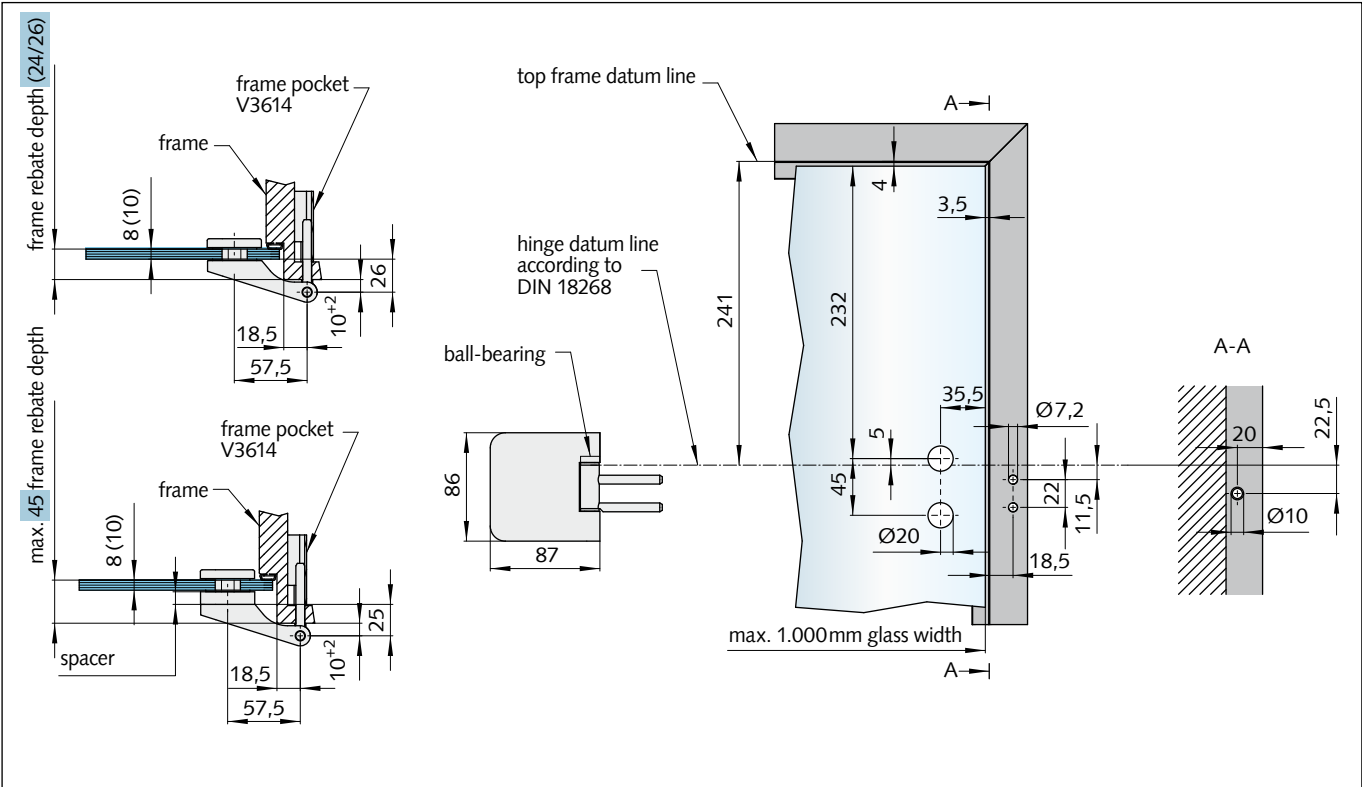

Hinge with frame part for wooden frames
 Part# 21.300.0500.--- to 21.310.0520.--- + 21.400.0000.010
 Part# 21.900.0500.--- to 21.910.0520.--- + 21.400.0000.010

Frame rebate depth	max. door weight
24 mm.....	45 kg
26–45 mm.....	42 kg

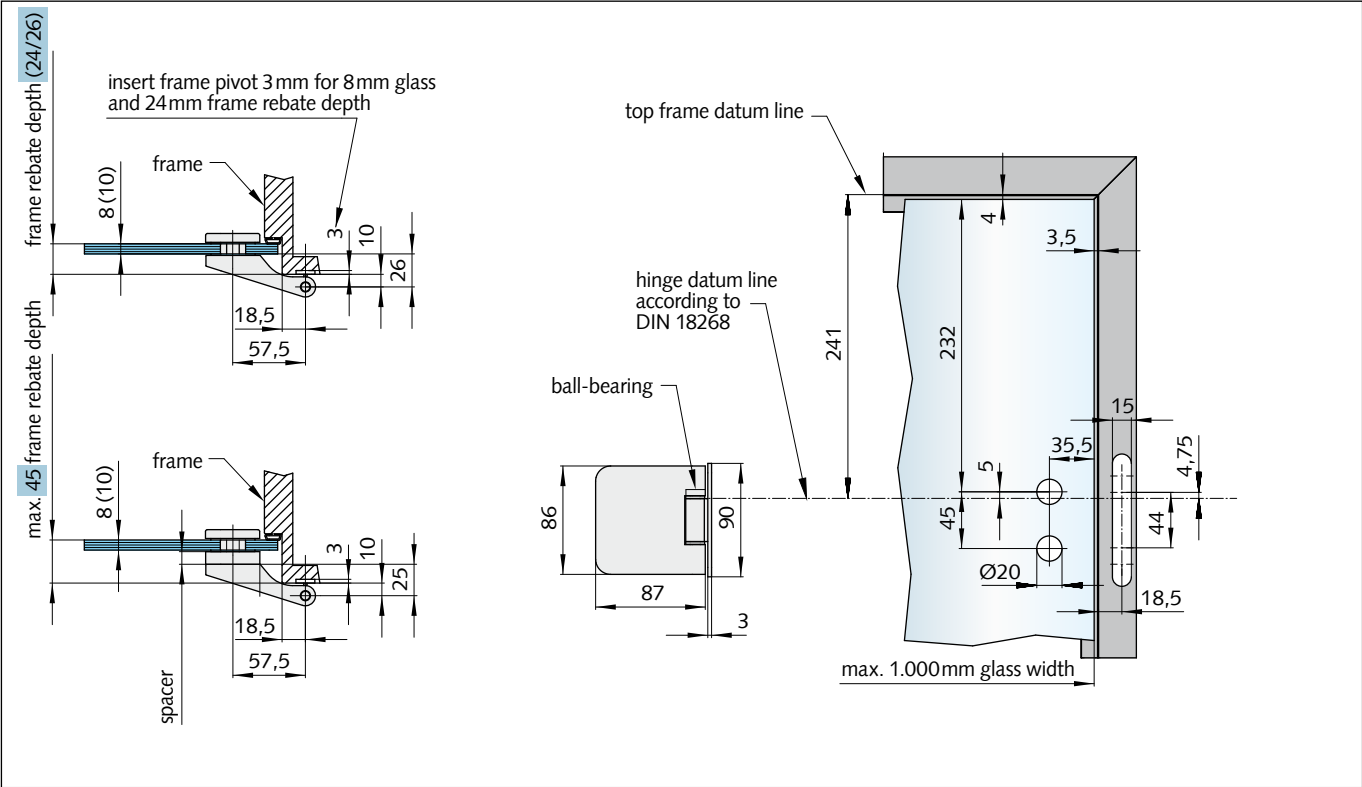

Hinge with frame part for wooden, steel and aluminium frames
 Part# 21.300.0500.--- to 21.310.0520.--- + 21.402.0000.010
 Part# 21.900.0500.--- to 21.910.0520.--- + 21.402.0000.010

Frame rebate depth	max. door weight
24 mm.....	45 kg
26–45 mm.....	42 kg

Installation details

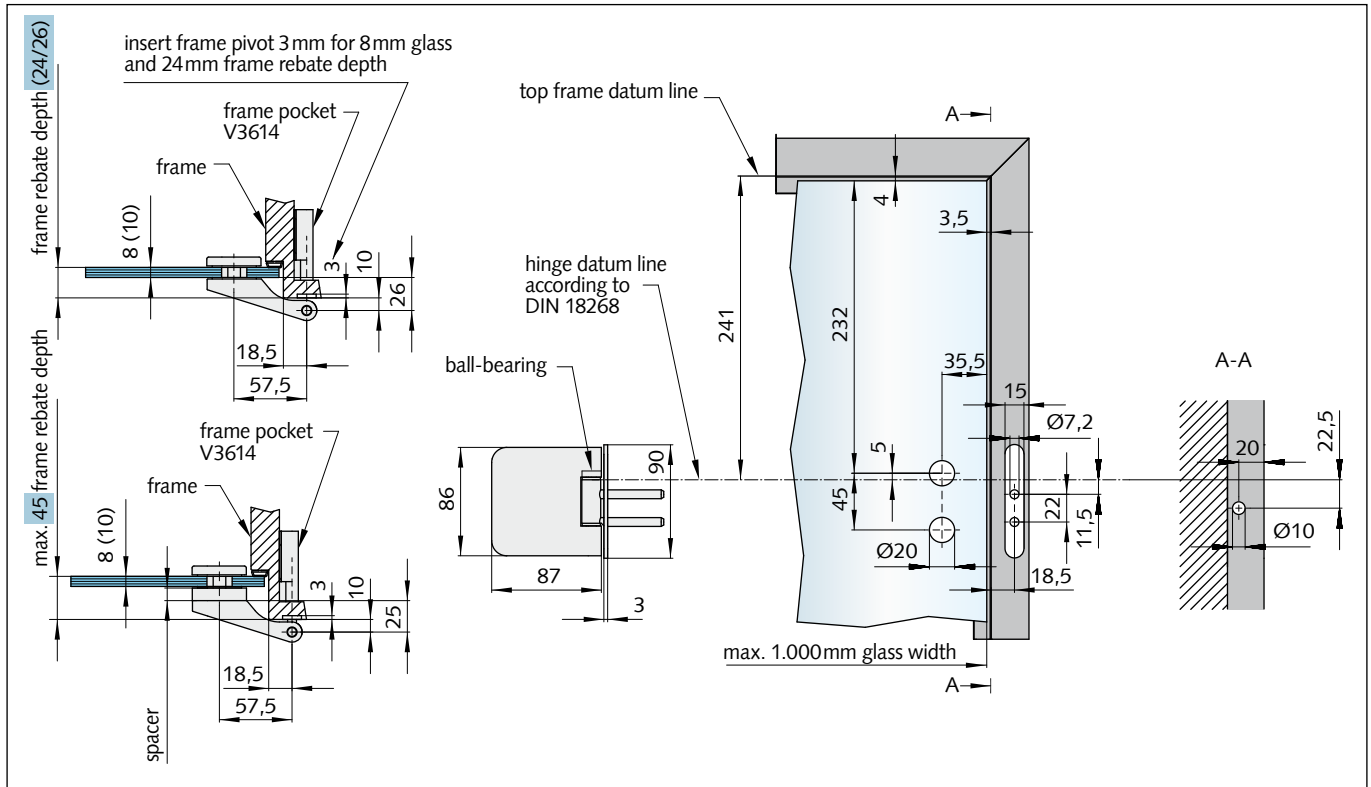

Hinge with frame part for wooden frames
 Part# 21.300.0500.--- to 21.310.0520.--- + 21.404.0000.010
 Part# 21.900.0500.--- to 21.910.0520.--- + 21.404.0000.010

Frame rebate depth	max. door weight
24 mm.....	47 kg
26–45 mm.....	47 kg

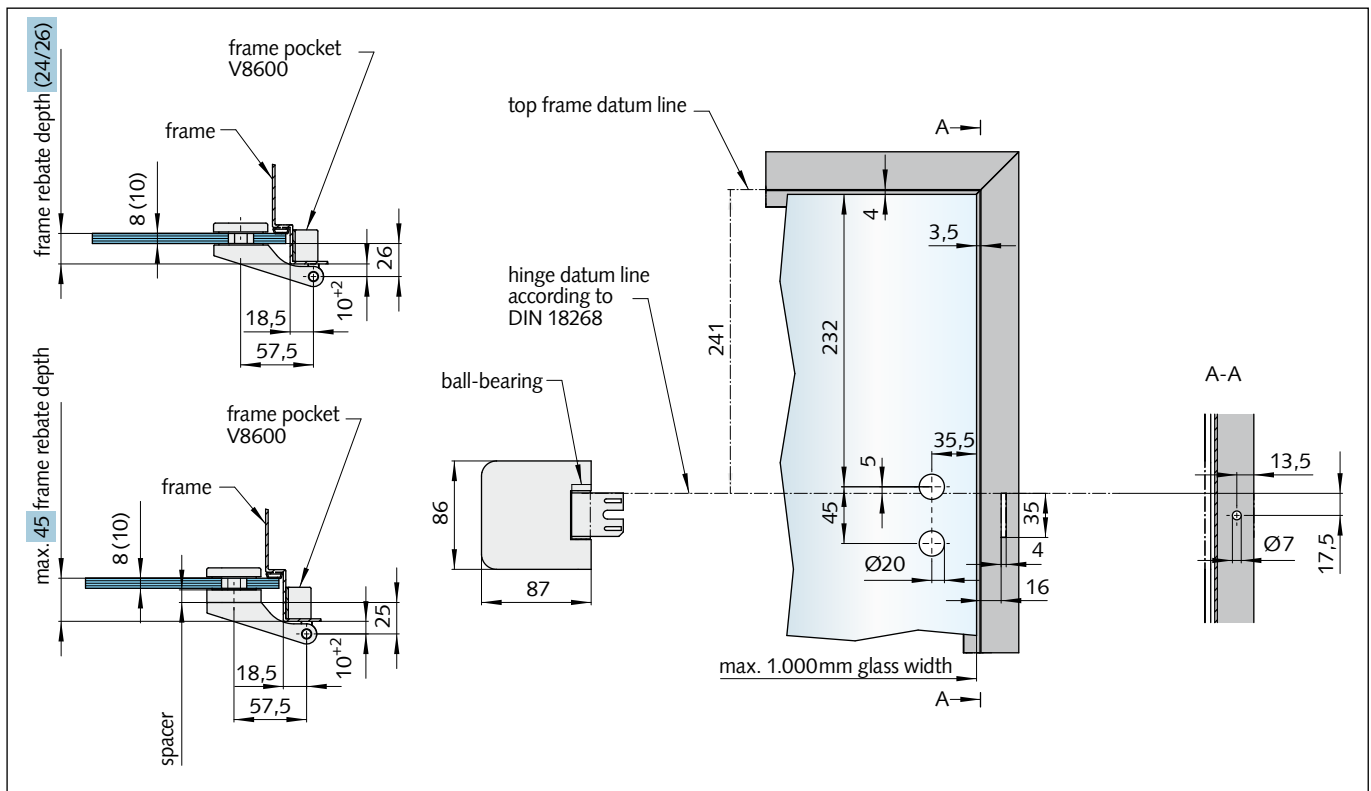

Hinge with frame part for steel frames
 Part# 21.300.0500.--- to 21.310.0520.--- + 21.420.0000.010
 Part# 21.900.0500.--- to 21.910.0520.--- + 21.420.0000.010

Frame rebate depth	max. door weight
24 mm.....	45 kg
26–45 mm.....	42 kg

Installation details

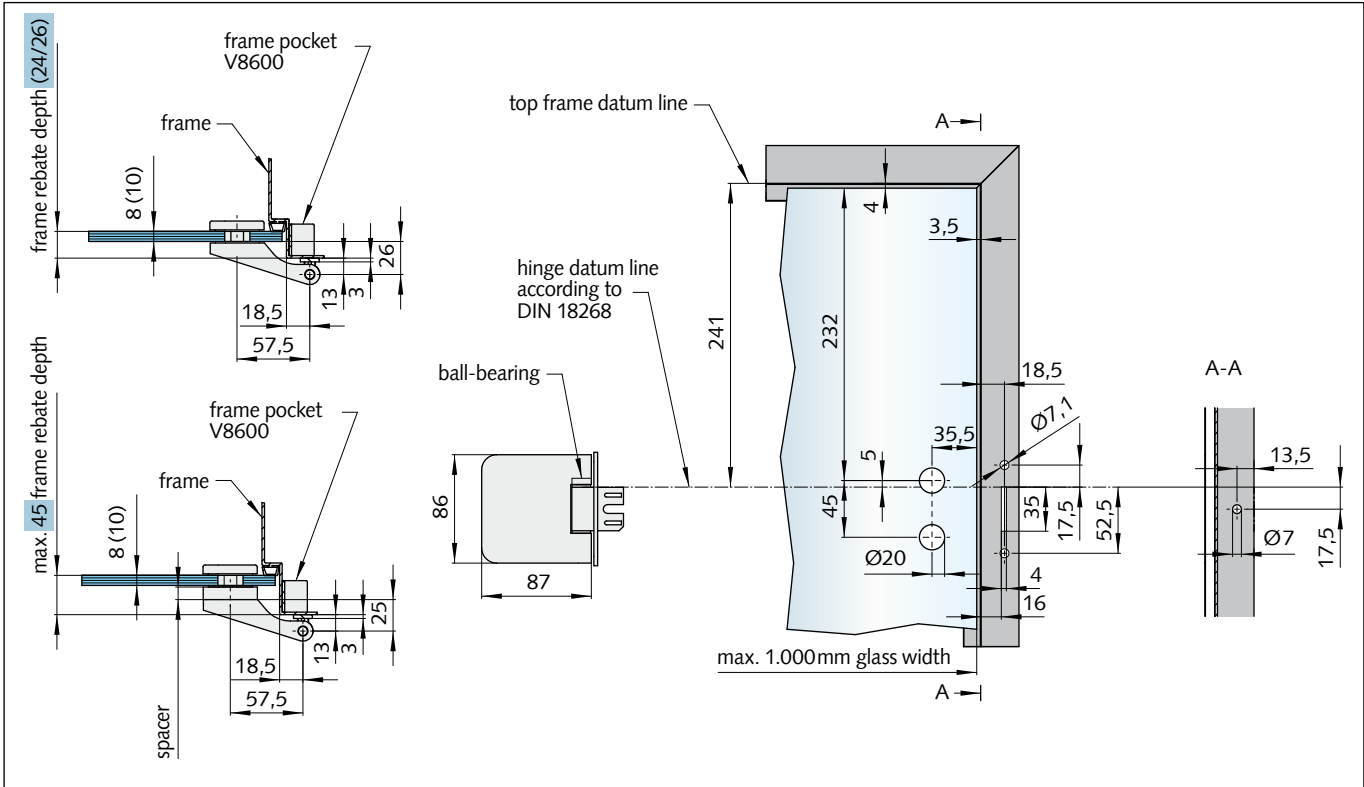

Hinge with frame part for steel frames
 Part# 21.300.0500.--- to 21.310.0520.--- + 21.422.0000.010
 Part# 21.900.0500.--- to 21.910.0520.--- + 21.422.0000.010

Frame rebate depth	max. door weight
24 mm.....	47 kg
26–45 mm.....	47 kg

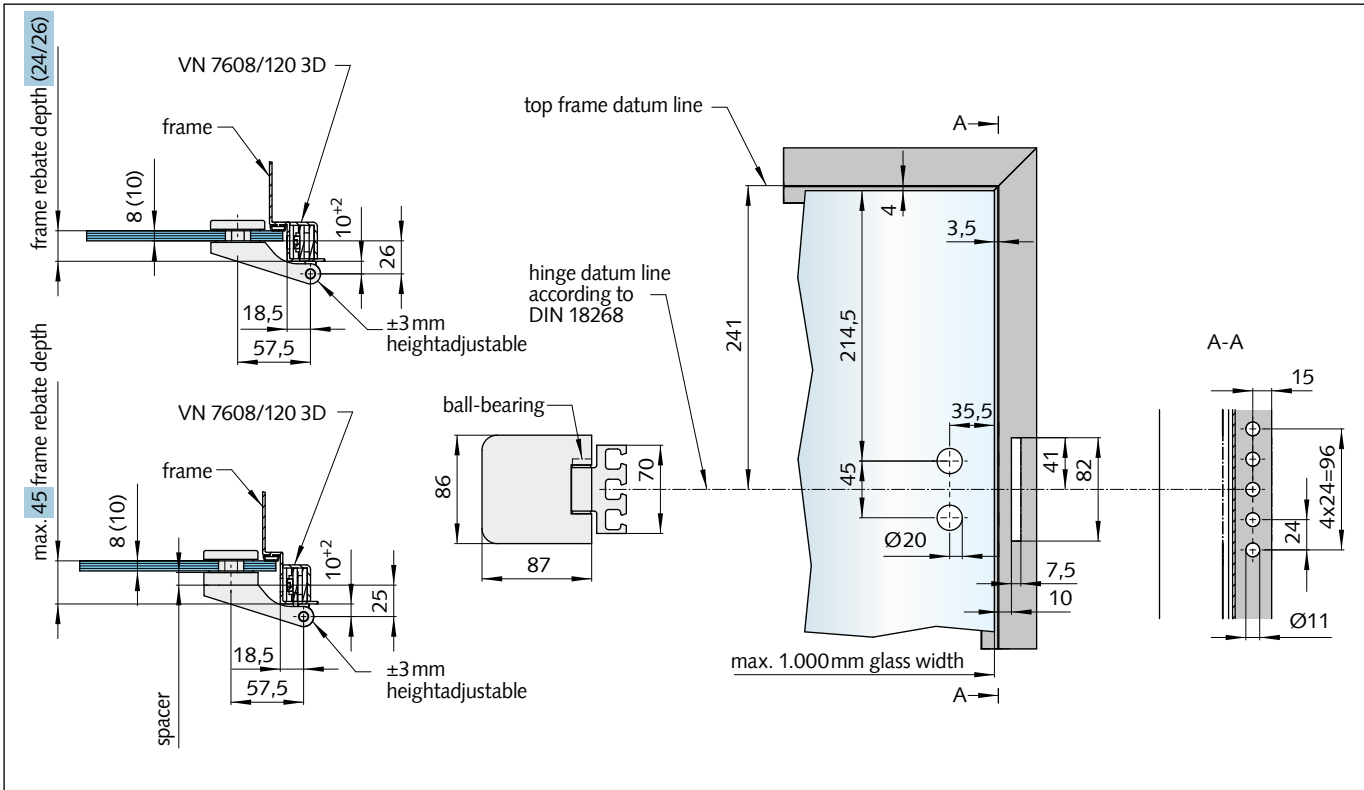

Hinge with frame part for steel frames
 Part# 21.300.0500.--- to 21.310.0520.--- + 21.424.0000.010
 Part# 21.900.0500.--- to 21.910.0520.--- + 21.424.0000.010

Frame rebate depth	max. door weight
24 mm.....	60 kg
26–45 mm.....	48 kg

Installation details

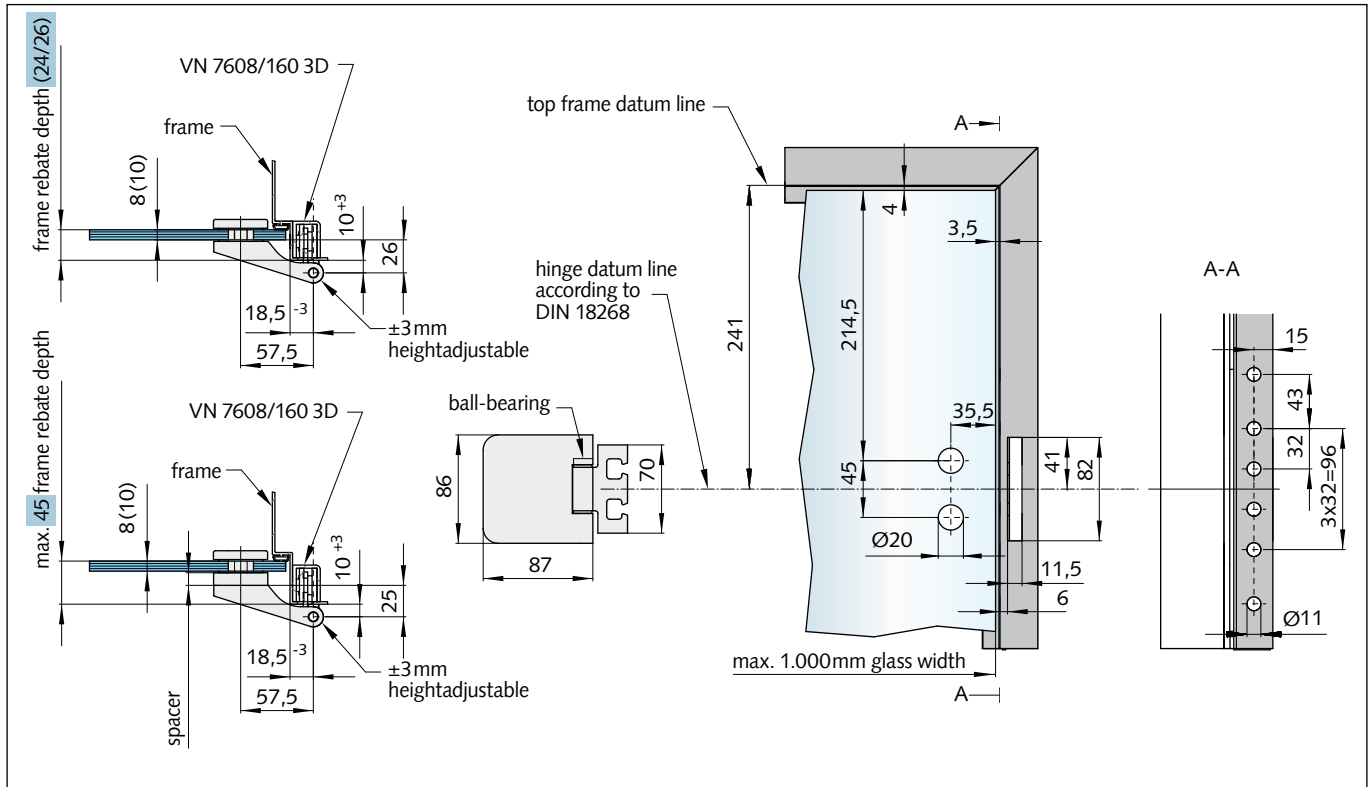

Hinge with frame part for steel frames

Part# 21.300.0500.--- to 21.310.0520.--- + 21.426.0000.010
 Part# 21.900.0500.--- to 21.910.0520.--- + 21.426.0000.010

Frame rebate depth	max. door weight
24 mm.....	60 kg
26–45 mm.....	48 kg

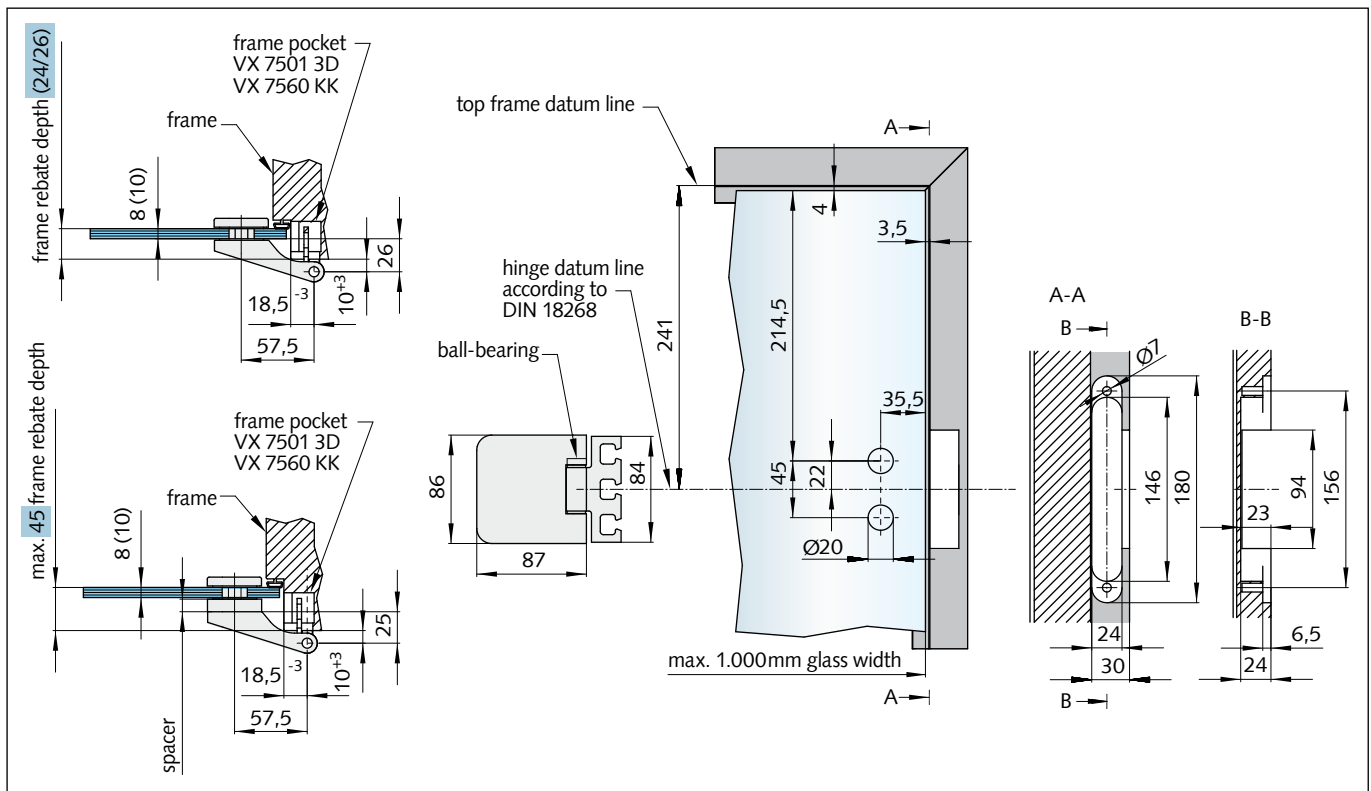

Hinge with frame part for wooden, steel and aluminium frames

Part# 21.300.0500.--- to 21.310.0520.--- + 21.440.0000.010
 Part# 21.900.0500.--- to 21.910.0520.--- + 21.440.0000.010

Frame rebate depth	max. door weight
24 mm.....	60 kg
26–45 mm.....	48 kg

Materials and finishes

Steel

- 010 = Galvanized
- 035 = Silver lacquered

Aluminium

Anodized according to EURAS standard colour swatch and standard colours (dip colouring):

- 112 = E4/C-0 silver anodized
- 114 = E6/C-0 silver anodized
- 137 = E4/C-31 stainless steel anodized
- 139 = E6/C-31 stainless steel anodized
- 174 = Polished chrome
- 198 = Stainless steel finish
- 199 = In special colour anodized

Powder-coated (70% gloss level):

- 250 = RAL 9010 pure white powder coated
- 295 = RAL powder coated

Brass

- 325 = Matt nickel plated

Stainless steel

- 416 = Stainless Steel 304 polished
- 426 = Stainless Steel 304 matt brushed

Plastic

- 505 = Natural
- 550 = White
- 565 = Black
- 570 = Grey

Pre-treatment

- E4 = Polished and brushed
- E6 = Chemical etching

Aluminium



E4/C-0 silver anodized
(---.112)



E4/C-31 stainless steel
anodized (---.137)



Polished chrome (---.174)



Stainless steel finish (---.198)

Stainless steel



Stainless Steel 304 polished
(---.416)



Stainless Steel 304 matt
brushed (---.426)

Information

The choice of available materials and finishes may differ for individual products.

The colour samples are for your guidance only.
Differences in colour are possible due to printing.

Slight deviations in colour are possible on account of the materials and manufacturing process.

The dimensions of items made of different materials may differ slightly from those shown in the images.

Other finishes are possible. Please contact us if you require these.

Index

Part#	Page	Part#	Page	Part#	Page	Part#	Page	Part#	Page
01.901.3131.325	59	20.147.0500.---	11	20.227.6500.---	14	20.512.1411.---	24	20.620.5411.---	28
01.903.3131.325	59	20.147.1500.---	12	20.235.0500.---	15	20.512.1421.---	24	20.620.5421.---	28
01.913.3131.325	59	20.147.2500.---	13	20.235.5500.---	15	20.512.2411.---	25	20.620.6411.---	28
01.914.3131.325	59	20.149.0500.---	11	20.235.6500.---	15	20.512.2421.---	25	20.620.6421.---	28
06.400.0000.---	58	20.149.1500.---	12	20.245.0500.---	15	20.513.0411.---	23	20.621.0411.---	28
20.100.0500.---	11	20.149.2500.---	13	20.245.5500.---	15	20.513.0421.---	23	20.621.0421.---	28
20.100.1500.---	12	20.200.0500.---	14	20.245.6500.---	15	20.513.1411.---	24	20.621.5411.---	28
20.100.2500.---	13	20.200.6500.---	14	20.254.0500.---	17	20.513.1421.---	24	20.621.5421.---	28
20.101.0500.---	11	20.201.0500.---	14	20.255.0500.---	17	20.513.2411.---	25	20.621.6411.---	28
20.101.1500.---	12	20.201.6500.---	14	20.257.0500.---	17,29	20.513.2421.---	25	20.621.6421.---	28
20.101.2500.---	13	20.202.0500.---	14	20.277.0411.---	16	20.514.0412.---	23	20.622.0412.---	29
20.102.0500.---	11	20.202.6500.---	14	20.277.0421.---	16	20.514.0422.---	23	20.622.0422.---	29
20.102.1500.---	12	20.203.0500.---	14	20.277.5411.---	16	20.514.1412.---	24	20.622.5412.---	29
20.102.2500.---	13	20.203.6500.---	14	20.277.5421.---	16	20.514.1422.---	24	20.622.5422.---	29
20.103.0500.---	11	20.204.0500.---	14	20.277.6411.---	16	20.514.2412.---	25	20.622.6412.---	29
20.103.1500.---	12	20.204.5500.---	14	20.277.6421.---	16	20.514.2422.---	25	20.622.6422.---	29
20.103.2500.---	13	20.204.6500.---	14	20.287.0412.---	17	20.515.0412.---	23	20.623.0412.---	29
20.104.0500.---	11	20.205.0500.---	14	20.287.0422.---	17	20.515.0422.---	23	20.623.0422.---	29
20.104.1500.---	12	20.205.5500.---	14	20.287.5412.---	17	20.515.1412.---	24	20.623.5412.---	29
20.104.2500.---	13	20.205.6500.---	14	20.287.5422.---	17	20.515.1422.---	24	20.623.5422.---	29
20.105.0500.---	11	20.206.0500.---	15	20.287.6412.---	17	20.515.2412.---	25	20.623.6412.---	29
20.105.1500.---	12	20.206.5500.---	15	20.287.6422.---	17	20.515.2422.---	25	20.623.6422.---	29
20.105.2500.---	13	20.206.6500.---	15	20.300.0500.---	18	20.546.0500.---	23	20.625.0500.---	26
20.106.0500.---	11	20.207.0500.---	15	20.302.0401.---	18	20.546.1500.---	24	20.625.6500.---	26
20.106.1500.---	12	20.207.5500.---	15	20.304.0402.---	18	20.546.2500.---	25	20.627.0500.---	26
20.106.2500.---	13	20.207.6500.---	15	20.306.0901.---	18	20.547.0500.---	23	20.627.6500.---	26
20.107.0500.---	11	20.210.0500.---	15	20.308.0902.---	18	20.547.1500.---	24	20.635.0500.---	27
20.107.1500.---	12	20.210.5500.---	15	20.310.0500.---	18	20.547.2500.---	25	20.635.5500.---	27
20.107.2500.---	13	20.210.6500.---	15	20.312.0500.---	18	20.549.0500.---	23	20.635.6500.---	27
20.112.0411.---	11	20.220.0411.---	16	20.318.0500.---	18	20.549.1500.---	24	20.645.0500.---	27
20.112.0421.---	11	20.220.0421.---	16	20.500.0500.---	23	20.549.2500.---	25	20.645.5500.---	27
20.112.1411.---	12	20.220.5411.---	16	20.500.1500.---	24	20.600.0500.---	26	20.645.6500.---	27
20.112.1421.---	12	20.220.5421.---	16	20.500.2500.---	25	20.600.6500.---	26	20.654.0500.---	29
20.112.2411.---	13	20.220.6411.---	16	20.501.0500.---	23	20.601.0500.---	26	20.655.0500.---	29
20.112.2421.---	13	20.220.6421.---	16	20.501.1500.---	24	20.601.6500.---	26	20.677.0411.---	28
20.113.0411.---	11	20.221.0411.---	16	20.501.2500.---	25	20.602.0500.---	26	20.677.0421.---	28
20.113.0421.---	11	20.221.0421.---	16	20.502.0500.---	23	20.602.6500.---	26	20.677.5411.---	28
20.113.1411.---	12	20.221.5411.---	16	20.502.1500.---	24	20.603.0500.---	26	20.677.5421.---	28
20.113.1421.---	12	20.221.5421.---	16	20.502.2500.---	25	20.603.6500.---	26	20.677.6411.---	28
20.113.2411.---	13	20.221.6411.---	16	20.503.0500.---	23	20.604.0500.---	26	20.677.6421.---	28
20.113.2421.---	13	20.221.6421.---	16	20.503.1500.---	24	20.604.5500.---	26	20.687.0412.---	29
20.114.0412.---	11	20.222.0412.---	17	20.503.2500.---	25	20.604.6500.---	26	20.687.0422.---	29
20.114.0422.---	11	20.222.0422.---	17	20.504.0500.---	23	20.605.0500.---	26	20.687.5412.---	29
20.114.1412.---	12	20.222.5412.---	17	20.504.1500.---	24	20.605.5500.---	26	20.687.5422.---	29
20.114.1422.---	12	20.222.5422.---	17	20.504.2500.---	25	20.605.6500.---	26	20.687.6412.---	29
20.114.2412.---	13	20.222.6412.---	17	20.505.0500.---	23	20.606.0500.---	27	20.687.6422.---	29
20.114.2422.---	13	20.222.6422.---	17	20.505.1500.---	24	20.606.5500.---	27	20.700.0500.---	30,40
20.115.0412.---	11	20.223.0412.---	17	20.505.2500.---	25	20.606.6500.---	27	20.702.0401.---	30,40
20.115.0422.---	11	20.223.0422.---	17	20.506.0500.---	23	20.607.0500.---	27	20.704.0402.---	30,40
20.115.1412.---	12	20.223.5412.---	17	20.506.1500.---	24	20.607.5500.---	27	20.706.0901.---	30,40
20.115.1422.---	12	20.223.5422.---	17	20.506.2500.---	25	20.607.6500.---	27	20.708.0902.---	30,40
20.115.2412.---	13	20.223.6412.---	17	20.507.0500.---	23	20.610.0500.---	27	20.710.0500.---	30,40
20.115.2422.---	13	20.223.6422.---	17	20.507.1500.---	24	20.610.5500.---	27	20.712.0500.---	30,40
20.146.0500.---	11	20.225.0500.---	14	20.507.2500.---	25	20.610.6500.---	27	20.718.0500.---	30,40
20.146.1500.---	12	20.225.6500.---	14	20.512.0411.---	23	20.620.0411.---	28	20.801.0500.---	35
20.146.2500.---	13	20.227.0500.---	14	20.512.0421.---	23	20.620.0421.---	28	20.801.1500.---	36

Part#	Page	Part#	Page	Part#	Page
20.801.2500.---	37	21.906.0901.---	31	26.202.0900.---	56
20.803.0500.---	35	21.908.0902.---	31	26.204.0400.---	56
20.803.1500.---	36	21.910.0510.---	31	26.204.0900.---	56
20.803.2500.---	37	21.910.0520.---	31	26.206.0000.010	57
20.805.0500.---	35	21.920.0500.---	31, 41	26.300.0600.---	57
20.805.1500.---	36	22.100.0000.---	44	26.301.0000.426	57
20.805.2500.---	37	22.104.0000.---	44	26.310.0000.565	57
20.807.0500.---	35	22.108.0000.---	44	26.320.0000.570	58
20.807.1500.---	36	22.112.0000.---	45	26.330.0000.505	58
20.807.2500.---	37	22.130.0000.426	45	26.332.0000.505	58
20.809.0500.---	35	22.134.0000.426	45	26.400.0500.426	58
20.809.1500.---	36	22.138.0000.426	46	26.404.0000.426	59
20.809.2500.---	37	22.142.0000.426	46	26.700.0500.035	54
20.841.0500.---	38	22.150.0000.---	46	26.702.0500.035	54
20.841.6500.---	38	22.154.0000.---	47	26.710.0500.035	55
20.843.0500.---	38	22.156.0000.---	47	26.712.0500.035	55
20.843.6500.---	38	22.158.0000.---	47	99.110.0000.999	59
20.845.0500.---	38	22.200.0000.---	44		
20.845.5500.---	38	22.204.0000.---	44		
20.845.6500.---	38	22.208.0000.---	44		
20.847.0500.---	39	22.212.0000.---	45		
20.847.5500.---	39	22.230.0000.426	45		
20.847.6500.---	39	22.234.0000.426	45		
20.849.0500.---	39	22.238.0000.426	46		
20.880.0500.---	41	22.242.0000.426	46		
20.882.0401.---	41	22.250.0000.---	46		
20.884.0402.---	41	22.254.0000.---	48		
20.886.0901.---	41	22.256.0000.---	48		
20.888.0902.---	41	22.258.0000.---	48		
20.890.0510.---	41	26.102.0400.---	52		
20.890.0520.---	41	26.104.0400.---	52		
20.902.0000.010	49	26.106.0400.---	52		
20.904.0000.010	49	26.132.0400.---	52		
20.906.0000.010	49	26.134.0400.---	52		
20.912.0000.010	49	26.136.0400.---	52		
20.922.0000.010	49	26.162.0000.505	52		
20.924.0000.010	49	26.164.0000.505	52		
21.300.0500.---	19	26.166.0000.505	52		
21.302.0401.---	19	26.170.0400.---	53		
21.304.0402.---	19	26.172.0400.---	53		
21.306.0901.---	19	26.174.0400.---	53		
21.308.0902.---	19	26.176.0900.---	53		
21.310.0510.---	19	26.178.0900.---	53		
21.310.0520.---	19	26.180.0900.---	53		
21.320.0500.---	19	26.182.0400.---	53		
21.400.0000.010	50	26.184.0400.---	53		
21.402.0000.010	50	26.186.0400.---	53		
21.404.0000.010	50	26.188.0900.---	53		
21.420.0000.010	50	26.190.0900.---	53		
21.422.0000.010	51	26.192.0900.---	53		
21.424.0000.010	51	26.194.0000.---	53		
21.426.0000.010	51	26.196.0000.---	53		
21.440.0000.010	51	26.198.0000.---	53		
21.900.0500.---	31	26.200.0000.114	56		
21.902.0401.---	31	26.201.0000.550	56		
21.904.0402.---	31	26.202.0400.---	56		

General Overview: Locks and Fittings for Glass

Catalogue



STUDIO Hardware
New perspectives through innovations. Top quality finishes. Locks and hinges for residential homes and commercial properties – with magnetic latches too.

Catalogue



OBJEKT Hardware
A variety of possibilities. Top quality finishes. Locks and hinges for commercial properties – for panic doors too.

Catalogue



SPRINT Sliding Door Systems
Space-saving and multi-functional, with SOFT-STOP, dual system and low-energy drive. Open up your rooms with SPRINT!

Basic catalogue



Locks and fittings for glass

The complete catalogue contains all products for interior- and exterior doors.

Brochure



SELCO – Self-closing double action door hinges

The new door hinges for interior doors in the private and commercial sector. Max. door weight 70 kg.

Brochure



Locks and patch fittings for exterior doors

Flexible and logical: Reassuring and reliable security for all-glass constructions.



Download:
<https://www.wss.de/en/service/kataloge/glas>



Wilh. Schlechtendahl & Söhne
GmbH & Co. KG

Hauptstrasse 18–32
42579 Heiligenhaus
Germany

Phone: +49 (0) 20 56/17-0
Fax: +49 (0) 20 56/51 42

wss@wss.de
www.wss.de

Legal venue 42579 Heiligenhaus,
District Court Wuppertal, HRA 20804

Managing Directors: Guido Lücker, Robin Fasel

VAT ID No.: DE 121546484
Tax no.: 13957280071

All images, product, dimensions and design details are related to the date of publishing. We reserve the right to changes in the interests of technical progress and further developments. No liability for printing errors or other technical mistakes. No legal claims of whatever kind can be derived from the use of our documents. Reprints of this document, even in part, require our written approval.

Express reference is made to our general terms and conditions of business, available at www.wss.de.