

# Hardware Solution for Doors

Sv Panic Locks Series 200

Panic Strike Box Series 200

Standard and Panic Locks Series 200

Design-Line Panic Bar Handle

Concealed Opening Restrictor

WSS Fittings for Entrance Doors

Barrel Hinges, Aluminium Door Hinges



## Design meets Technology

The new series 200 Sv panic locks, with mechanical and mechatronic model, meet the requirements of emergency exit doors and panic doors of modern building technology. The decisive thing is that all relevant locking and function modes can be queried via integrated sensor technology.

Thanks to the electronic lever handle coupling, integration in building control systems, time recording and other such functions are also possible. The new Design Line panic bar handle offers an appropriate function-orientated design to match the locks. While the clear and purist look is convincing, the intelligent geometry enables maximum freedom from restraint, even with small door widths.

The new, concealed WSS opening restrictor is ideal for doors where the limit stop shall be secured and a fixation of the door shall be possible. The adjustable holding force and the integrated end damping allow the use of doors up to 120kg. Through the use of opening restrictors, the use of doorstops and door-stays becomes unnecessary and therefore no risk of tripping arises – ideal for public, private and especially barrier-free areas.

Diversification of the WSS product range for entrance doors: Door handles with exchangeable inlays, optionally supplied with a fingerprint scanner, new, flush-mounted WSS door fittings and flat reinforced fascia plates, both made out of honed stainless steel complement the product line.

We pursue a policy of consistent product and product range optimisation of our hinges. The stainless steel and aluminium barrel hinges are both functional and aesthetic. Convenient to install with technical features demanded on a modern barrel door hinge.

The 3D-PLUS door hinge is also innovative: Door weights up to 180kg, generous adjustment options and can be upgraded up to class RC 3/SKG\*\* – an all-rounder.

## Content

Sv Panic Lock Series 200 Functions B and E.....	Page 3
Sv Panic Lock Series 200 Electronic Handle Control .....	Page 4
Panic Strike Box Series 200.....	Page 6
Standard and Panic Locks Series 200 .....	Page 8
Design-Line Panic Bar Handle .....	Page 10
Concealed Opening Restrictor .....	Page 12
WSS Fittings for Entrance Doors .....	Page 13
Aluminium Door Hinges 3D-PLUS.....	Page 14
Barrel Hinge RB-T.....	Page 16
Aluminium Barrel Hinge RB-R .....	Page 18

# Inner Values Count.

## Sv Panic Lock Series 200 Functions B and E



### Application – oriented functionality

Ongoing technical development has resulted in the design of the new Sv panic locks series 200. These new Sv panic locks with integrated query sensor technology combine precision engineering and electronic monitoring. The integrated automatic locking system of the reversible latch does not require a separate triggering mechanism. Adjustment to gap dimensions is no longer necessary.

Universal application with right-left use together with the added option of a variable escape direction allows for reduced warehousing. The new Sv panic lock is available for single and double-leaf door systems.

The conical bolt with a 20 mm throw provides for secure and fast locking. The Sv panic lock is available with an additional lock to the top for large door heights. The 12 or 16 mm stroke provides for good security coverage between locking rod and strike plate in the event of a change in climatic conditions or of fire. A mechanical bolt arrester can be integrated into the system if electronic door openers are used.

#### Sv panic lock series 200 functions B and E are suitable for:

- Single and double-leaf doors in combination with WSS panic fittings and certified door handles
- Automated door and alarm security systems

#### Technical features:

- Tests according to DIN EN 1634 and DIN EN 12209
- Integrated query sensor technology (optional)
- Secure latch and bolt arrester (function E) (optional)
- Latch and bolt arrester (function B) (optional)
- Reversible latch with integrated trigger
- Variable escape direction
- Integrated follower query for access control (optional)
- Bolt query for automated door and alarm systems (optional)
- Cylinder query for alarm security systems / panic activation (optional)

#### Dimensions:

Box dimensions: .....200 x 15.5 mm / 250 x 15.5 mm  
Backsets: .....Flat front plate 35, 40 and 45 mm  
                       U front plate 34 and 39 mm  
Rear backset:..... 15 mm  
Bolt throw: .....20 mm



# Solutions for more Security



## Sv Panic Lock Series 200 Electronic Handle Control



### Consistently innovative

The new Sv panic lock with integrated door handle control and query sensor technology combines complex mechanics and electronic control.

With electronic Sv panic locks, the external door handle is activated by means of an integrated control and can be regulated with a separate operating unit.

The reversible latch with integrated trigger and optional variable escape route reduce warehousing considerably.

The new Sv panic lock is available for single and double-leaf door systems and has a bolt throw of 20mm. In addition, a forced closure function C is integrated, which ensures that authorized keyholders such as operational or emergency personnel secure the building when they are leaving it.

The Sv panic lock is also available with an additional top locking for high door leaves. The 12 or 16mm stroke provides for good security coverage between locking rod and strike plate in the case of a change in climatic conditions or of fire. A mechanical, secured bolt arrester can be integrated into the system if electronic door openers are used.

**The Sv panic lock series 200 electronic handle control is suitable for:**

- Single and double-leaf doors according to DIN EN 179 and DIN EN 1125 in combination with WSS panic fittings and certified door handles
- Automated door and alarm security systems



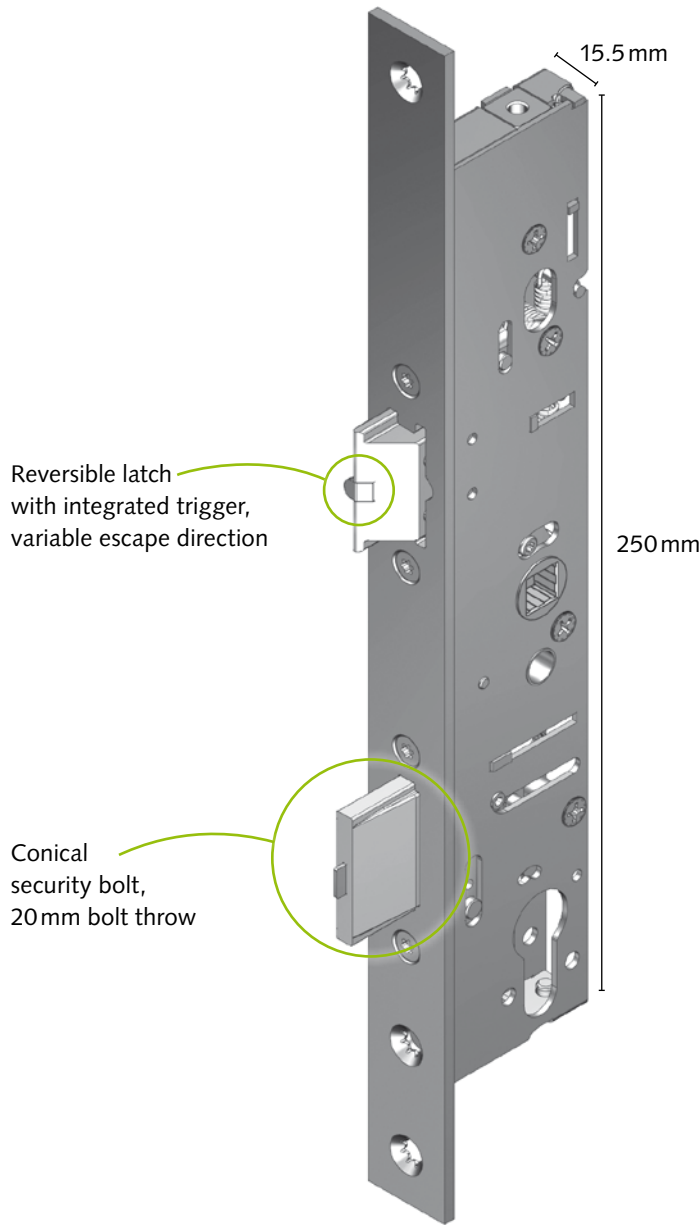

#### Technical features:

- 12-24 VDC, min. 1 A
- Tests according to DIN EN 1634, DIN EN 12209 and DIN EN 14846
- Integrated control
- Integrated query sensor technology
- Reversible latch with integrated trigger
- Variable escape direction
- Forced closure function C
- Integrated follower query for access control
- Bolt query for automated door systems and alarm security
- Cylinder query for alarm security systems / panic activation

#### Dimensions:

Box dimensions: .....250 x 15.5 mm  
 Backsets: .....Flat front plate 35, 40 and 45 mm  
   U front plate 34 and 39 mm  
 Rear backset:.....15 mm  
 Bolt throw: .....20 mm

#### A variety of application options:

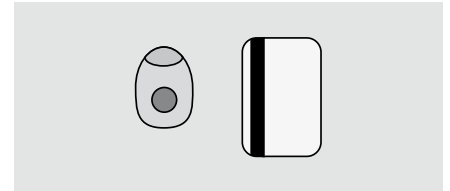

Opening using a transponder (access control). Transponder as a keyring or ISO card.

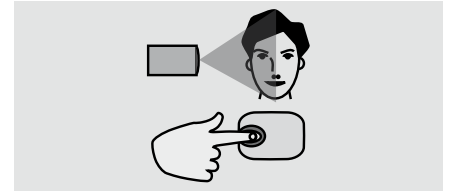

Highest building security due to biometric components (facial recognition and finger scan).



Easy programming and central administration of access authorisation using a PC.



Time management by using RFID technology.



External devices such as rolling gates and barriers in car parks can be controlled with a single transponder.

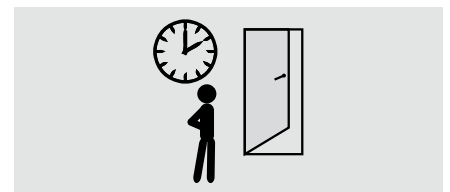

Permanent access for the public using the function "constant open".



# Clever and Compact

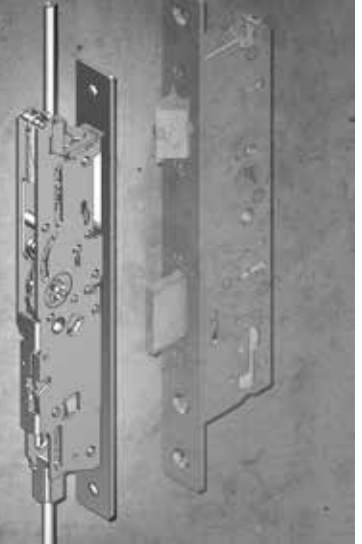

## Panic Strike Box Series 200



### A practical new development

The new series 200 panic strike box adapts to the diverse profile geometries available on the market. To achieve this, an adjustable bolt ejector was designed, which can bridge gaps between 4–8 mm. There is no need to fit a backing on the forend.

An additional new development is the patented mounting technology of the lock elements. These are no longer drilled or pinned but are simply hammered. The special holder brush provides for a permanent connection. A 20 mm rod stroke ensures secure locking, even in the case of high door leaves.

The new special function for high-traffic entrance areas: an optional rod arrester fixes the locking elements such that both door leaves can remain permanently open. When the door leaf is closed, automatic locking is not triggered, door contact only occurs with the door closer. This is a considerable advantage, particularly in areas where people gather.

A query sensor system for follower activation and bolt contact is optionally available.

#### The strike box series 200 is suitable for:

- Double-leaf doors, testing according to DIN EN 179 and DIN EN 1125, in combination with WSS panic fittings and certified door handles

#### Technical features:

- Tests according to DIN EN 1634
- Adjustable bolt ejector
- Patented mounting for locking pieces
- Optional with rod arrester

#### Dimensions:

Box dimensions: .....200 x 15.5 mm  
Backsets: .....Flat front plate 35, 40, 45, 55 und 65 mm  
                                U front plate 34 and 39 mm  
Rod stroke:.....20 mm

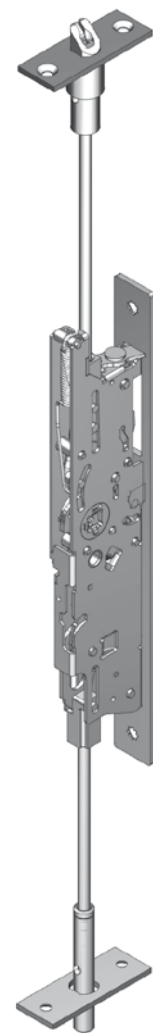

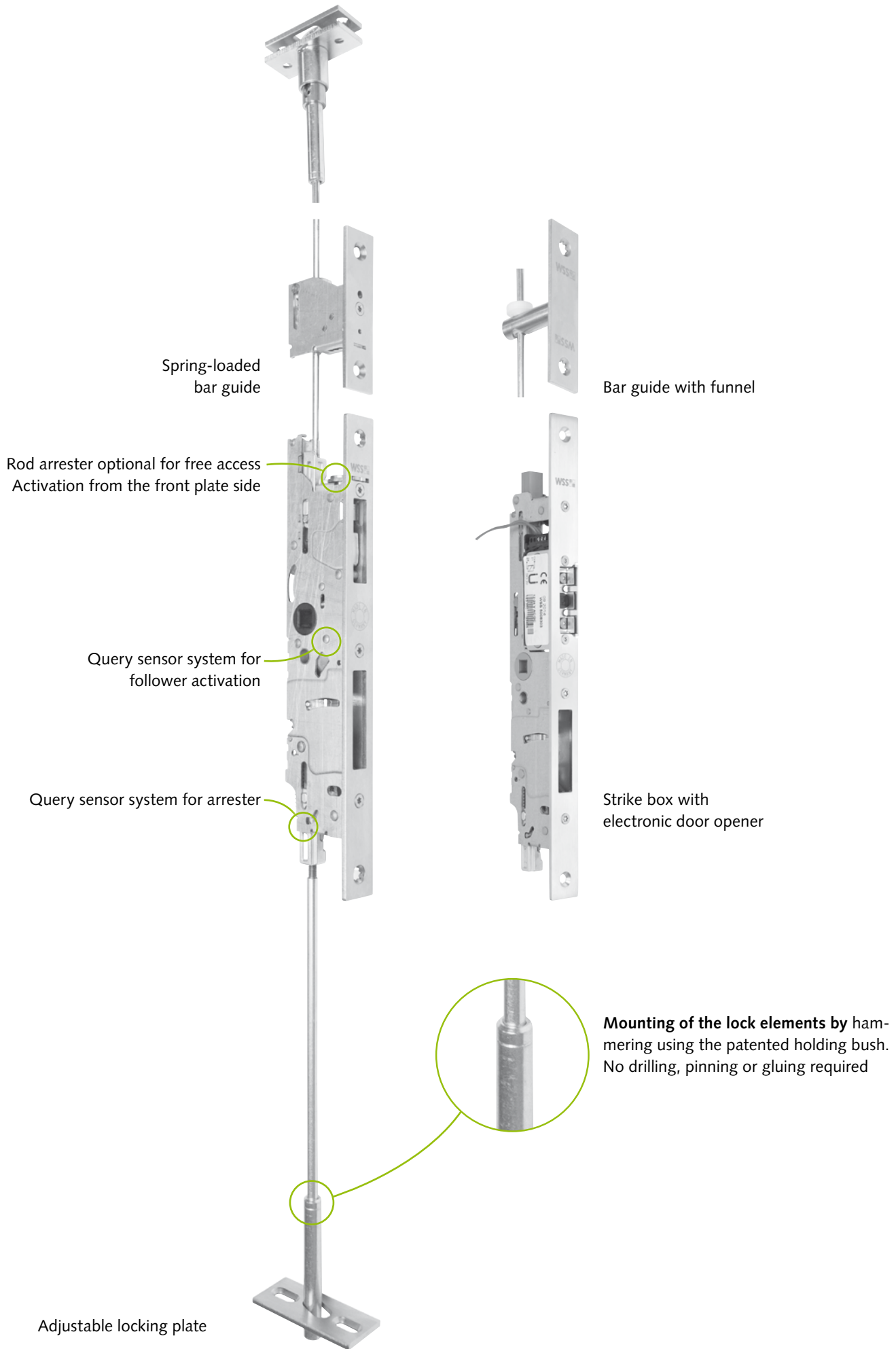

# More Standard Functions



## Standard and Panic Locks Series 200



### A great line

The new series 200 standard and panic locks, available as mechanical and mechatronic models, complement the Sv panic 200 lock series. All relevant lock and functional modes can be queried via integrated sensor technology. The new panic strike box, with or without the Sv panic series electronic door openers, can also be used here. The reversible latch and variable escape direction reduces the warehousing considerably.

Combined with certified lever door handles or WSS panic bar handles and push bars, the locks are approved according to DIN EN 179 and 1125.

The conical bolt shape with a bolt throw of 20mm guarantees reliable locking. All locks are also available with additional top locking.

The standard has been extended to door heights up to 3,000mm, as a result, a spring-loaded bar guide has been developed. The bar guide can be adjusted in three steps, even after installation, as the setting can be changed from the front plate side using a special tool. Another new development is the bar guide with funnel – this makes it considerably easier to insert the bar and reduces installation times.

#### Standard and panic locks series 200 are suitable for:

- Single and double-leaf doors according to DIN EN 179 and DIN EN 1125 in combination with WSS panic fittings and certified lever door handles

#### Technical features:

- Tests according to DIN EN 1634 and DIN EN 12209
- Integrated query sensor technology (optional)
- Secure latch arrester (function E)
- Reversible latch
- Variable escape direction
- Integrated follower query for access control (optional)
- Bolt query for automated door and alarm systems (optional)
- Cylinder query for alarm security systems / panic activation (optional)





Spring bolt lock



Spring-loaded bar guide



Bar guide with funnel



**Dimensions:**

Box dimensions: .....200 x 15.5 mm / 250 x 15.5 mm

Backsets: .....Flat front plate 35, 40 and 45 mm  
U front plate 34 and 39 mm

Rear backset..... 15 mm

Bolt throw .....20 mm

# Design meets Technology

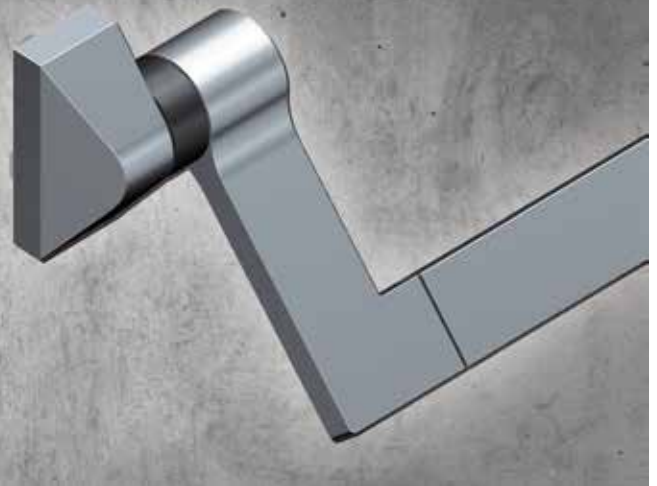

## Design-Line Panic Bar Handle



### Function-orientated design

The new developed panic bar handle does not only attracts attention due to its clear, purist design. The clever arrangement of the minimalist components ensures maximum freedom from restraint, even with narrow door widths. Thus, there are almost no limits to the design freedom of the designer.

Thanks to the compact design, narrow profile elevation widths can also be implemented. The cap width of only 32 mm prevents projection into the glass strip and emphasises the elegant optic. High-quality materials and top workmanship round off the profile.

The high-quality aluminium surface is supplied with a stainless steel optic or other anodizing colours.



## LED technology

The new panic bar handle is also available with optional LED technology in RGB colours. This not only assists intuitive use in case of an emergency, but can also be integrated in the building's lighting design concept.



Spacer with LED



Aluminium anodised spacer



Black plastic spacer

### Technical features:

- Right/left use
- Rose or short backplate available
- Aluminium stainless steel finish or anodised
- Optional LED lighting of the intermediate rings is compatible with the standard LED driver steps for controlling the colour and colour temperature
- Simple ergonomic installation without visible screw fixing, without special tools

### Technical details:

Cover cap dimensions: ..... L: 75 mm, W: 32 mm, H: 37.5 mm

Upstand height: ..... 99 mm (according to DIN EN 1125 / class 2)  
to ensure the largest possible passage widths

Follower rotating angle: ..... Continuously adjustable up to 45°



# Rapidly installed or upgraded

## Concealed Opening Restrictor

### Opening restrictor for doors with an adjustable hold-open device

The concealed WSS opening restrictor for aluminium doors is due to its minimal installation dimensions and its easy assembly ideal for doors, where the limit stop shall be secured and a fixation of the door shall be possible.

The opening restrictor was especially designed for the use with profile frame doors. Therefore you only need a milling in the upper sash or frame profile. The adjustable holding force and the integrated end damping are an ideal way of protecting the concealed door hinges and allow the use of doors up to 120 kg.

Through the use of the opening restrictor, the use of doorstops and door-stays becomes unnecessary and therefore no risk of tripping or bruises arises. Furthermore, floor heating systems and high quality floor coverings stay intact and untouched – ideal for public, private and especially barrier-free areas.

#### Technical features:

- Right/left usable
- Space requirements 570 x 24 x 44 mm
- Door width 890 mm to 1.400 mm
- Max. door weight 120 kg
- Rest position from 45° up to 105°
- Selectable opening angle up to 105°
- Integrated end damping

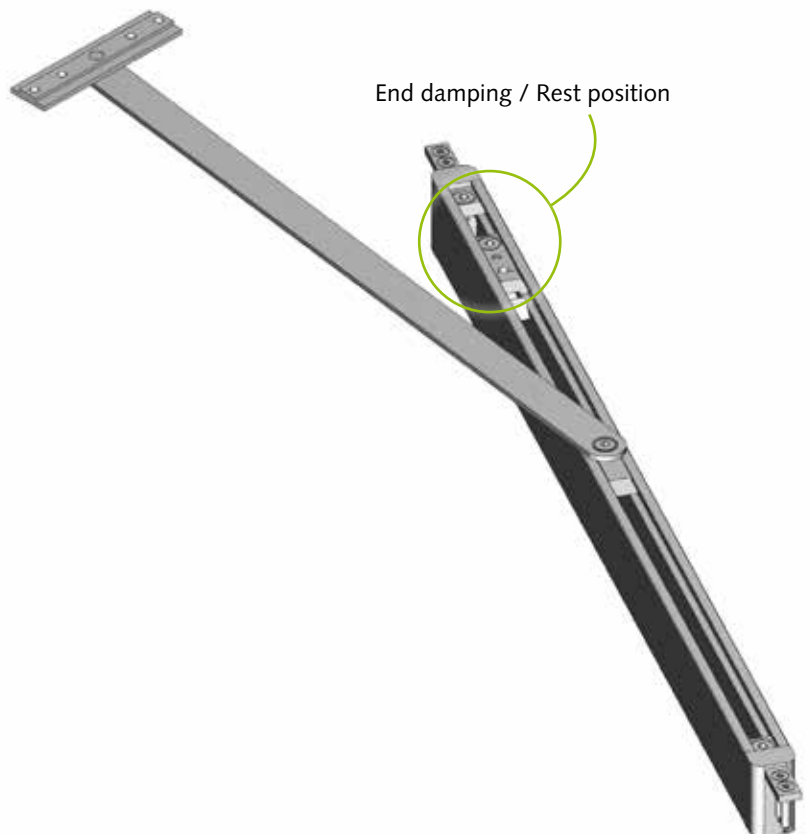

# Security and Design



## WSS Fittings for Entrance Doors

The WSS product range of private entrance doors for single and multi-family homes is characterized by its large number of product varieties. The wide choice in the fields of: Door handles and knobs, door hinges as well as locks for tubular frames allow the creation of individually configurable fitting sets. Everything under one roof – one manufacturer, one contact partner for all components. The ideal solution for processors, manufacturers and distributors.

### Door handles with fingerprint scanner

Modern entrance doors are characterized through the use of various materials and surfaces such as wood, glass or stainless steel. This modern material-combination is reflected in the design of the new WSS door handles. The handle insert can be realized in different RAL colors or as a ceramic inlay, but also different materials are possible – perfect for an individual design. Optionally, the handle can be supplied with an integrated fingerprint scanner.



### Flush-mounted door handles for light-metal doors

The new, flush mounted WSS door fittings made out of honed stainless steel underline the high quality of the door element. Aesthetics and elegance are expressed through a distinctive look and touch. They literally insert themselves seamlessly into high quality materials and surfaces.



### Flat reinforced fascia plates made out of stainless steel

The flat stainless steel reinforced fascia plates protect the profile cylinder against manipulation and prevent the cylinder core of being pulled out.

### 3D-PLUS door hinges

The innovative 3D-PLUS door hinge: Door weights up to 180kg, generous adjustment facilities and upgradeable up to class RC3 – a true all-rounder. The color can be adapted to the overall design of the door. Besides all anodized shades, the 3D-PLUS hinges are also available in all RAL colors.





# 3D Dimensional adjustable

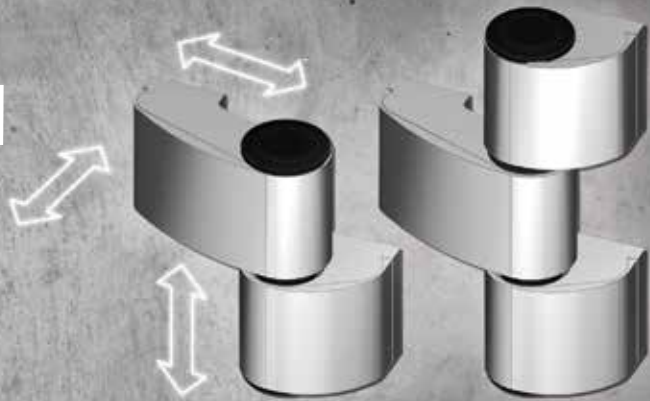

## Aluminium Door Hinges 3D-PLUS



### Flexible in all respects

The further developed 2 and 3-piece door hinge, 3D-PLUS is impressive due to its sophisticated design and its many potential applications for doors with a leaf weight of up to max. 180kg.

Direct screw connection, screw inserts or counter plate: Three different fixing techniques allow for the use of virtually any profile shape.

Our 3D-PLUS door hinges are also suitable for use with anti-burglar doors: SKG\*\*, DIN EN 1627 RC2 (WK2) and DIN EN 1627 RC3 (WK3).

The colour versions can be matched to the overall design of the door system. In addition to all anodizing colours, WSS barrel hinges can be supplied in all RAL colours.

#### Technical features:

- Leaf weights of up to 180kg
- Quality-tested according to DIN EN 1935, class 13/14
- Infinite, three-dimensional adjustment
- Right/left use
- For 3, 5 and 10mm leaf projection
- Stainless steel hinge pins
- Maintenance-free plastic bearing bushes
- Rustproof materials

#### Areas of application:

Aluminium doors for private and commercial building sector, main entrance areas, side doors, internal doors, external doors, special-function doors

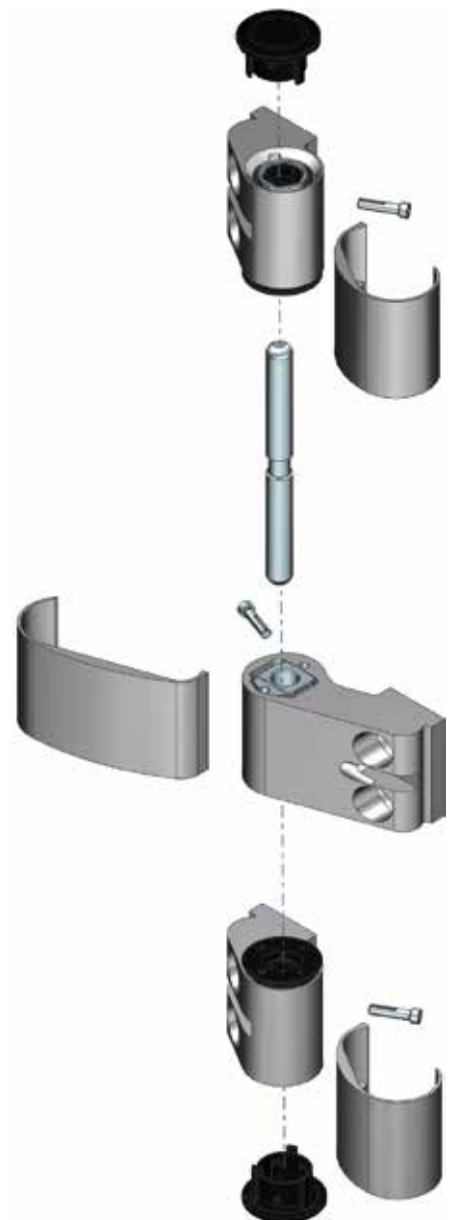

## Three fixing options



### Direct fixing using a screw:

- For inward and outward opening doors
- Replaces the mounting version "spacer sleeve with counter plate" for outward opening doors
- Ideal for retro-fitting or repair
- Fast assembly



### Fixing with screw inserts:

- For inward and outward opening doors
- Replacement for bridging the insulating chambers with spacer sleeves
- Ideal for retro-fitting or repair
- Easy assembly



### Fixing with counter plates:

- For inward opening doors
- For insulated and non-insulated profiles
- For pillar designs

## Resistance class RC3

The use of chuck profiles hinders any breaking of the 3D-PLUS door hinges. Therefore, their resistance class increases to RC3.

3-piece hinge with interlocking anti-jemmy for anti-burglar doors.

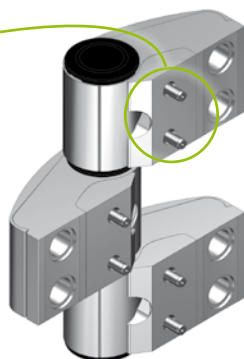

RC 3

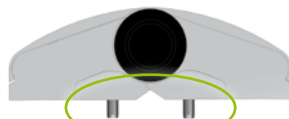

The interlocking anti-jemmy is fitted to the hinge part and door profile using a coiled spring pin.



Standard model round



Standard execution planar



# Slim in Nobel Steel

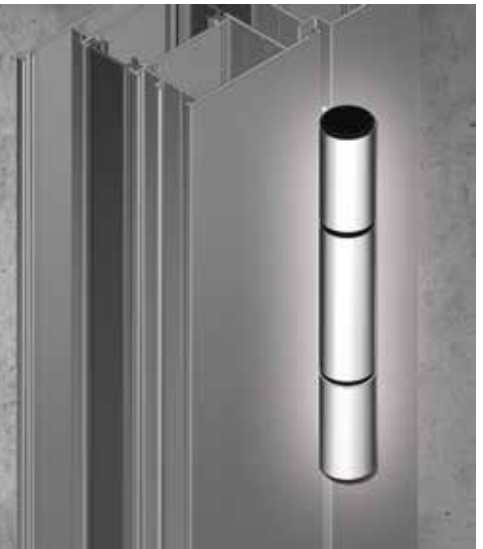

## Barrel Hinge RB-T

### Sophisticated design

and innovative technology, as well as the consequent use of high-quality materials and precise surface – this characterises the WSS stainless steel barrel hinge. This new generation of door hinge combines aesthetics with technology, providing sophisticated and modern doors with a superior design.

Despite the appearance of delicate optics, no concessions have been made in terms of technology or functionality. Continuous welded hinge rolls with a 22 mm Ø, a stainless steel hinge pin with 12 mm Ø and polyamide slide bearing allow the use of door weights of up to 160 kg.

The barrel hinges are tested according to DIN EN 1935:2002-5, class 14 and are also internally tested with 1,000,000 movement cycles on our own certified test stand without objection.



#### Rebate spacer adjustment with released fixing screws:

Rebate spacer in steps of 0.5 mm by adding or removing the spacer plates.



#### Height adjustment with released fixing screws:

Height adjustment  $\pm 3$  mm using a hexagonal height eccentric.



Inward opening version (fig. left)  
Outward opening version (fig. right)

As this door hinge is infinitely height adjustable  $\pm 3$  mm using an eccentric on the supporting hinge, it can be adapted to suit different floor coverings.

The rebate space is adjusted using stainless steel spacer plates in 0.5 mm steps  $\pm 1.5$  mm. You only have to release the fixing serews on the leaf-side of the fixing plate.

Mounting with counter plates on the profile.

**Technical features:**

- Tested quality according to DIN EN 1935:2002-5 / class 14
- Infinite height adjustment
- Rebate space adjustment in steps of 0.5 mm
- 160 kg load capacity (with two hinges)
- Continuous seal
- Right/left use
- Hinge roll continuously welded
- Optional available in polished stainless steel

**Technical details:**

Height adjustment:.....  $\pm 3$  mm  
 Rebate space adjustment: .....  $\pm 1.5$  mm  
 Hinge roll: .....  $\varnothing 22$  mm, length 171 mm

**Profile:**

TKI 755 opening inwards and outwards,  
 TKI 071 opening inwards and outwards, among others

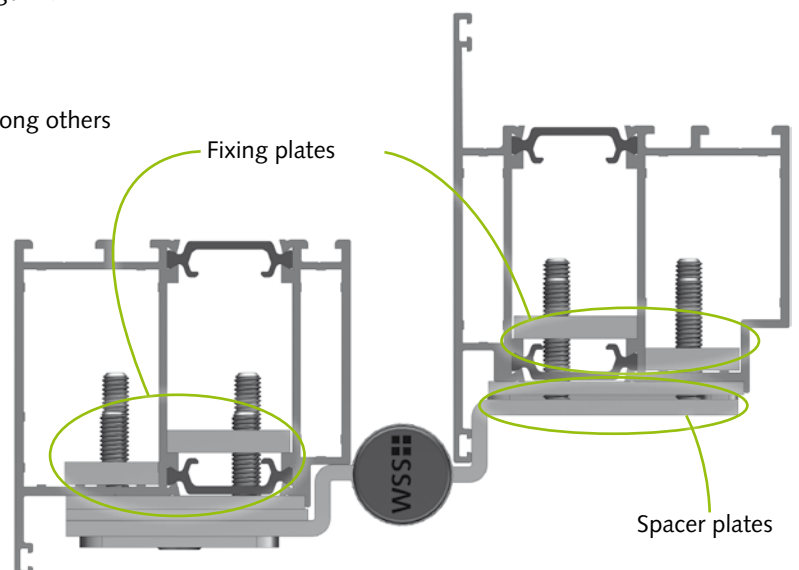

# Stylish Appearance, Technology Included



## Aluminium Barrel Hinge RB-R

### Systematic development and proven technology

The barrel hinge for aluminium doors for the private and commercial building sector is captivating not only for its attractive and slim appearance. It is also the technical features that make the WSS barrel hinge so appealing to architects and others working with it.

Despite the variety of profile geometries that already exist on the market, WSS has created two barrel hinge models – inwards and outwards – that are suitable for a substantial proportion of door profiles.

The 20mm slim hinge roll made of extruded aluminium profiles and a 10mm Ø stainless steel hinge bearing bolt vouch for their stability and allow door weights of up to 250 kg.

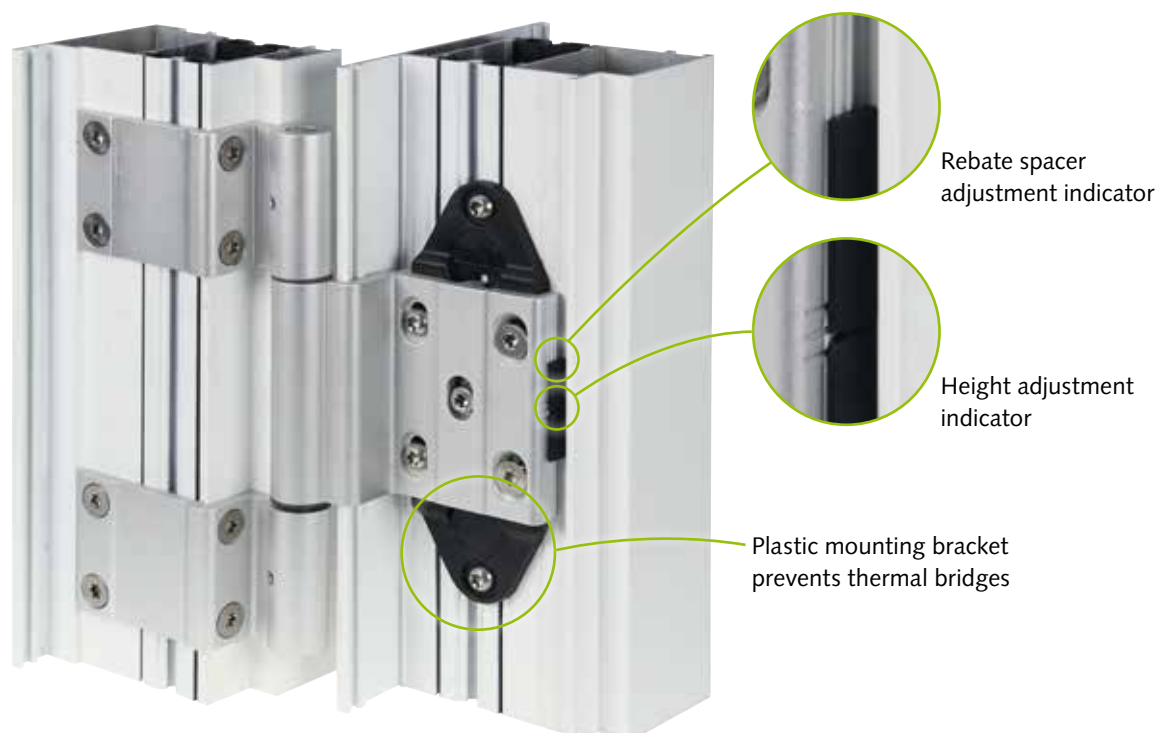



The barrel hinges are tested according to DIN EN 1935:2002-5, class 16 (tested to draft standard DIN EN 1935:2012-08) and are also internally tested with 1,000,000 movement cycles on our own certified test stand without objection.

Equipped with plastic fixing brackets on the leaf side, additional cold bridges are excluded.

The new continuous height adjustment is achieved by an eccentric on the lever hinge part when the door is hung in place, as well as adjustment of the rebate gap. To do this, only the leaf-side fixing screws in the fixing brackets are loosened. Both adjustment options can be set using a visual display.

The coloured variants can be adapted to the overall design of the door system; in addition to all anodizing colours, WSS barrel hinges can also be supplied in all RAL colours.

**Technical features:**

- Tested according to DIN EN 1935:2002-5 / class 16
- Continuous height adjustment
- Rebate gap adjustment
- 250 kg load-bearing capacity (with three hinges)
- Direct fixing on the door frame
- No cold bridges
- Right/left use
- All anodizing and RAL colours possible

**Technical details:**

Height adjustment:..... ±3 mm

Rebate spacer adjustment: ..... ±2 mm

Hinge roll: ..... Ø 22 mm, length 182 mm



Inward opening model



Outward opening model



**Wilh. Schlechtendahl & Söhne**  
GmbH & Co. KG

Hauptstrasse 18-32  
42579 Heiligenhaus  
Germany

Phone: +49 (0) 20 56/17-0  
Fax: +49 (0) 20 56/51 42

wss@wss.de  
www.wss.de

All image, product, dimension and design information is correct at the time of going to press. We reserve the right to make any changes that may be required for technical and further development. We assume no liability for printing or other errors. Legal claims, regardless of their nature, may not be inferred from the use of our documents. No part of this document may be reproduced without our prior written consent.