

Clamping rail



Clamping rail

Flexible and easy to assemble.
Discreet in appearance.



CONTENTS



Technical details

328



Materials and surface finishes

329

Product information

Clamping rail:

Standard 330

Security pin 330

Accessories 331



Technical details

Clamping rail

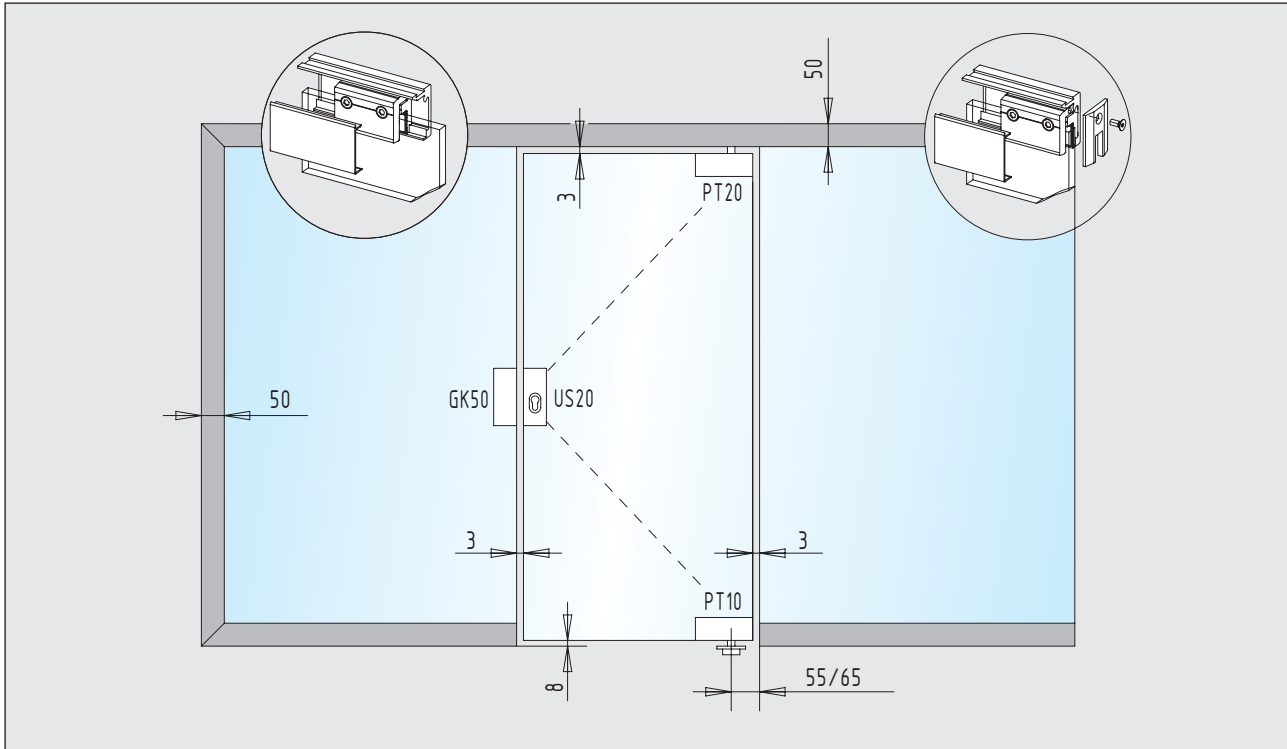

Glass preparation - clamping rail with security pin

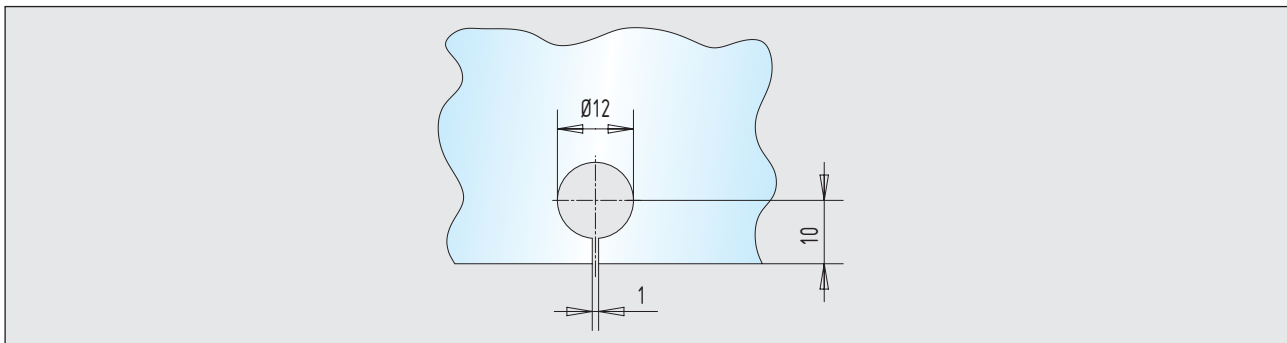

Technical Features

- Suitable for 8 - 12 mm thick glass
- Cover and base profile in aluminium
- Secondary covers in brass and stainless steel available
- **Adjustable position of glass clamps (3 pcs/metre)**
- Maximum load: 30 kg each glass clamp
- Base profile drilled every 300 mm (assembly on wall/ceiling)
- Stainless steel screws M6 (torque setting 10 Nm)
- **Facility available to insert top centre**
- No glass preparation required (exception: security pin)
- For overhead glazing - always use the security pin

Materials and surface finishes

Materials	Surface finishes code	Clamping rail
Aluminium	mill finish ... 105	●
	E4/C-0 silver ... 112	●
	RAL 9010 pure white ... 250	●
	RAL 9016 traffic white ... 255	●
	E4/S5/EV 5 similar gold ... 132	●
	E4/C 34 dark bronze ... 152	●
	E4/C 31 similar stainless steel ... 137	●
	special anodized ... 199	●
	RAL coated ... 295	●
Brass	polished ... 318	●
	matt brushed ... 328	●
Stainless Steel	satin ... 426	●
	polished ... 416	●

Information:

When using the clamping rail with brass or stainless steel covers the endcaps will be supplied in aluminium. These items will be supplied with a surface finish to match the covers.

The brass and stainless steel secondary covers are to be glued on top of the aluminium covers.





Standard / Security pin

- available in lengths up to 6.000 mm max.
- cover in aluminium in lengths up to 6.000 mm

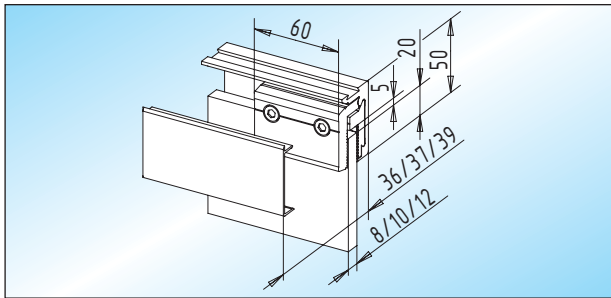

KR 50 - Clamping rail
clamping rail with base profile, glass clamps and cover

Glass	stock length	fixed length
8 mm	35.100.0400. ___	35.102.0400. ___
10 mm	35.100.0900. ___	35.102.0900. ___
12 mm	35.100.1100. ___	35.102.1100. ___

- cover in brass / stainless steel in lengths up to 2.000 mm

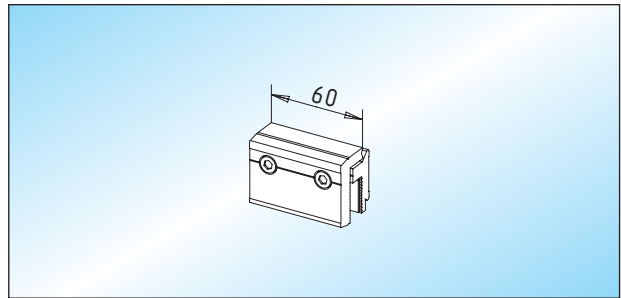

Glass clamp
aluminium glass clamp

Glass	stock length	fixed length
8 mm	35.204.0400.105	
10 mm	35.204.0900.105	
12 mm	35.204.1100.105	

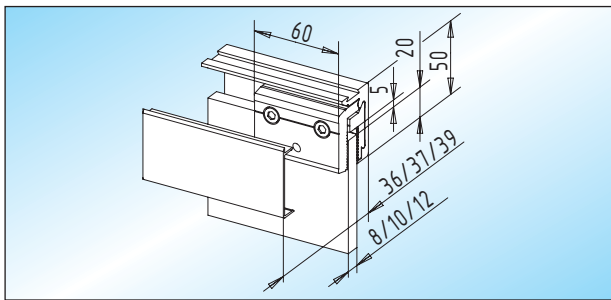

KR 50.1 - Clamping rail
clamping rail with base profile, glass clamps with security pin and cover. **Glass preparation: page 328**

Glass	stock length	fixed length
8 mm	35.110.0400. ___	35.112.0400. ___
10 mm	35.110.0900. ___	35.112.0900. ___
12 mm	35.110.1100. ___	35.112.1100. ___

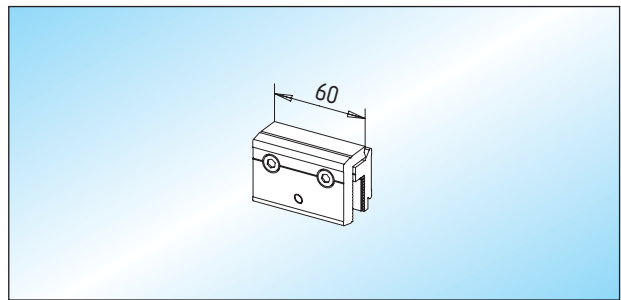

Glass clamp
aluminium glass clamp with security pin
Glass preparation: page 328

Glass	stock length	fixed length
8 mm	35.206.0400.105	
10 mm	35.206.0900.105	
12 mm	35.206.1100.105	

15

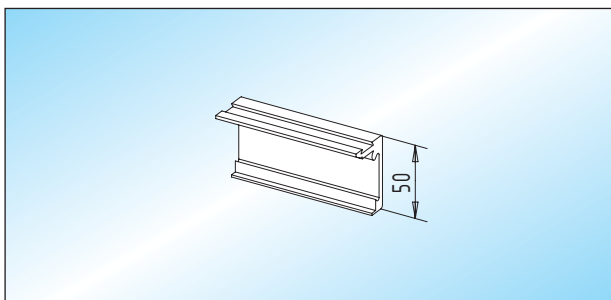

Base profile
aluminium base profile

stock length	35.200.0000. ___
fixed length	35.202.0000. ___

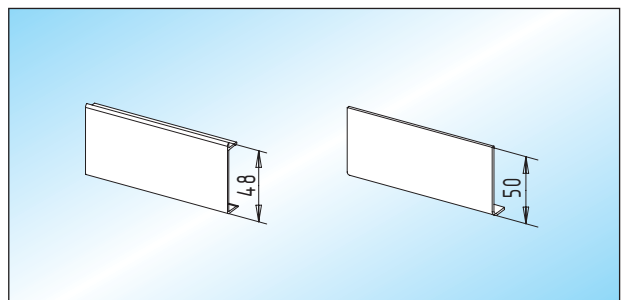

Cover
aluminium cover / 48 mm to clip on base profile
(only used one-side)

stock length	35.210.0000. ___
fixed length	35.212.0000. ___

Secondary cover
secondary cover / 50 mm in brass / stainless steel
(fixed on both sides)

stock length	35.220.0000. ___
fixed length	35.222.0000. ___

Accessories

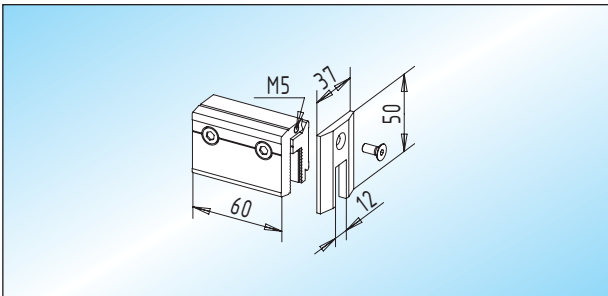

Endcap
aluminium endcap and glass clamp

Glass	
8 mm	35.300.0400. ____
10 mm	35.300.0900. ____
12 mm	35.300.1100. ____

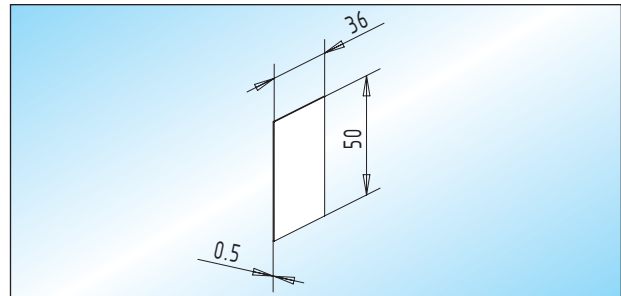

Endcap
aluminium endcap, self adhesive

Glass	
8 - 12 mm	35.304.0600. ____

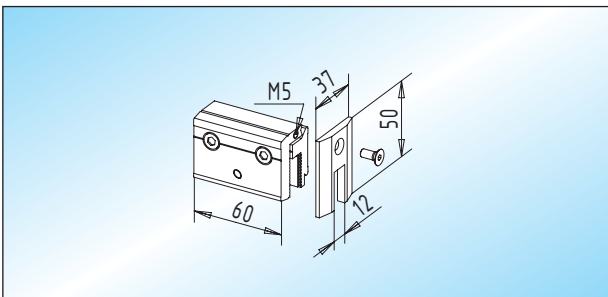

Endcap
aluminium endcap and glass clamp with security pin
Glass preparation: page 328

Glass	
8 mm	35.302.0400. ____
10 mm	35.302.0900. ____
12 mm	35.302.1100. ____

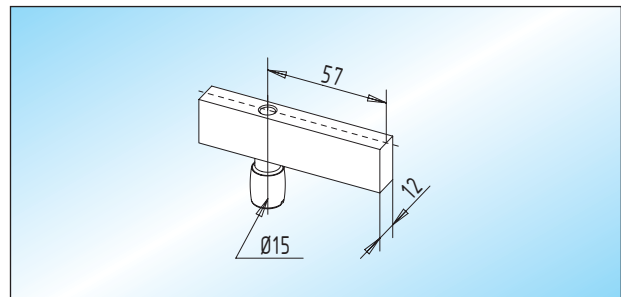

Top centre
aluminium top centre with stainless steel pivot pin

	35.306.0000.426
--	-----------------



Notes